

Data Sheet - Series 160, 161 and 162 Miniature Position Transducers

Analog-Output Miniature Position Transducers

Key Features

1. 42.5-Inch (1080-mm) Maximum Travel (Series 162)
2. Analog Signal Using Precision Conductive Plastic/Hybrid Potentiometers
3. AccuTrak™ Threaded Drum for Enhanced Repeatability
4. Bearing-Mounted Rotating Components
5. Optional Flexible Mounting Bases
6. DirectConnect™ Sensor-To-Drum Technology = Zero Backlash, No Torsion Springs or Clutches



Potentiometer Specifications

	1-turn	3-turn	5-turn
Potentiometer Type	1-turn, precision, conductive plastic	3-turn, precision, hybrid	5-turn, precision, hybrid
Resistance: Value, Tolerance	5K ohms, $\pm 20\%$	5K ohms, $\pm 5\%$	5K ohms, $\pm 5\%$
Travel: Electrical, Mechanical	340°, 360°	1080°, 1080° +10° -0°	1800°, 1800° +10° -0°
Mechanical Life	10 million shaft revolutions min	5 million shaft revolutions min	5 million shaft revolutions min
Output Signal	analog signal from 0 to supply voltage (voltage divider circuit)		
Power Rating	1.0 W at 158° F (70° C)	1.5 W at 158° F (70° C)	2.0 W at 158° F (70° C)
Supply Current	12 mA max		
Supply Voltage	35 VDC max (using voltage divider circuit)		
Independent Linearity Error	$\pm 1.0\%$ max per VRCl-P-100A	$\pm 0.5\%$ max per VRCl-P-100A	$\pm 0.35\%$ max per VRCl-P-100A
Output Smoothness	0.1% max	0.5% max	0.35% max
Insulation Resistance	100 Mohms at 1000 VDC min	1000 Mohms at 500 VDC min	1000 Mohms at 500 VDC min
Dielectric Strength	1000 VDC min	1000 VDC min	1000 VDC min
Resolution	infinite signal	infinite signal	infinite signal
Operating Temperature	-40° to 257° F (-40° to 125° C)	-67° to 257° F (-55° to 125° C)	-67° to 257° F (-55° to 125° C)
Electrical Connection	3-terminal (1, 2, 3)	3-terminal (CW, CCW, S)	3-terminal (CW, CCW, S)
Shock	50 g for 11 ms	100 g for 6 ms	100 g for 6 ms
Vibration	10 to 2000 Hz at 15 g	10 to 2000 Hz at 15 g	10 to 2000 Hz at 15 g
Temperature Coefficient	± 400 ppm/°C max	$\pm 0.007\%$ /°C max	$\pm 0.007\%$ /°C max

The potentiometer type of a specific position transducer part number is designated by the 8th digit of the part number counting left to right. Example: 160-0321-C5SS contains a 1-turn potentiometer while 161-2405-D7NU contains a 5-turn potentiometer.

Other Specifications

Case/Drum Materials	precision-machined anodized 2024 aluminum												
Displacement Cable	0.018-inch (0.46-mm) dia., 7-by-7 stranded stainless steel, 40-lb (177-N) min breaking strength												
Displacement Cable Hardware	1 each of 300196 loop sleeve, 300292 copper sleeve, 300688 ball-end plug, 300495 pull ring, 160026 brass swivel, and 301003 nickel swivel; all items provided uncrimped												
Electrical Connections	three solder terminals; electrical cable and connector options available												
Nominal Mass	<table style="width: 100%; border: none;"> <tr> <td style="text-align: center;">Series 160</td> <td style="text-align: center;">Series 161</td> <td style="text-align: center;">Series 162</td> </tr> <tr> <td style="text-align: center;">4 oz</td> <td style="text-align: center;">113 g</td> <td style="text-align: center;">6.1 oz</td> </tr> <tr> <td style="text-align: center;">113 g</td> <td style="text-align: center;">170 g</td> <td style="text-align: center;">9 oz</td> </tr> <tr> <td style="text-align: center;">9 oz</td> <td style="text-align: center;">255 g</td> <td style="text-align: center;">255 g</td> </tr> </table>	Series 160	Series 161	Series 162	4 oz	113 g	6.1 oz	113 g	170 g	9 oz	9 oz	255 g	255 g
Series 160	Series 161	Series 162											
4 oz	113 g	6.1 oz											
113 g	170 g	9 oz											
9 oz	255 g	255 g											
Environmental Protection	NEMA 4 / IP 56, DO-160D (ED-14D) Env. Cat. E1E1ABXHRFDFSAXXXXXXXXXXX (with optional sensor cover)												

Model Numbers and Ordering Codes

Model	Range		Nominal Displacement Cable Tension Range (Full Retraction to Full Extraction)							
	inches	mm	Opt 5: -.050 spring		Opt 6: -.060 spring		Opt 7: -.070 spring		Opt 8: -.080 spring	
			oz.	N	oz.	N	oz.	N	oz.	N
160-0161	2.00	51	9 to 15	3 to 4	16 to 25	4 to 7	30 to 37	8 to 10	40 to 55	11 to 15
160-0241	3.00	76	7 to 12	2 to 3	10 to 18	3 to 5	17 to 30	5 to 8	40 to 55	11 to 15
160-0321	4.00	102	4 to 8	1 to 2	5 to 12	1 to 4	12 to 20	3 to 6	28 to 55	7 to 16
160-0483	6.00	152	10 to 21	3 to 6	12 to 30	3 to 8	48 to 72	13 to 20	75 to 160	21 to 45
160-0643	8.00	203	7 to 17	2 to 5	9 to 24	3 to 7	22 to 38	6 to 11	40 to 120	11 to 33
160-0803	10.00	254	6 to 13	2 to 4	8 to 19	2 to 5	16 to 32	4 to 9	35 to 100	10 to 28
160-0963	12.00	305	5 to 11	1 to 3	7 to 19	2 to 5	14 to 27	4 to 8	24 to 82	7 to 23
160-1085	13.50	343	7 to 20	2 to 6	12 to 28	3 to 8	18 to 53	5 to 15	30 to 134	8 to 37

160-1285	16.00	406	6 to 17	2 to 5	8 to 24	2 to 7	19 to 40	5 to 11	17 to 102	5 to 28
160-1505	18.75	476	5 to 14	1 to 4	8 to 22	2 to 6	15 to 39	4 to 11	24 to 90	6 to 26
160-1705	21.25	540	5 to 12	1 to 3	7 to 19	2 to 5	12 to 33	3 to 9	14 to 79	4 to 22
161-0461	5.75	146	-	-	4 to 15	1 to 4	13 to 32	4 to 9	35 to 50	10 to 14
161-1283	16.00	406	-	-	6 to 12	2 to 3	10 to 25	3 to 7	14 to 70	4 to 19
161-1915	23.88	606	-	-	5 to 17	1 to 5	13 to 30	4 to 8	16 to 80	4 to 22
161-2145	26.75	679	-	-	7 to 14	2 to 4	10 to 25	3 to 7	11 to 60	3 to 17
161-2405	30.00	762	-	-	5 to 12	1 to 3	8 to 23	2 to 6	9 to 60	3 to 17
162-2735	34.13	867	-	-	-	-	8 to 21	2 to 6	10 to 55	3 to 15
162-2945	36.75	933	-	-	-	-	7 to 20	2 to 6	15 to 44	4 to 12
162-3205	40.00	1016	-	-	-	-	7 to 18	3 to 5	10 to 43	3 to 12
162-3405	42.50	1080	-	-	-	-	7 to 17	2 to 5	8 to 41	2 to 11

Bolded entries are standard cable tension.

Order Codes

16 - -abcd (example: 160-0321-S5SB (cable exit: slot, cable tension: -050, sensor cover, and base: big foot))

Series 160	a	S	cable exit: slot (60)
		C	cable exit: cable guide
		D	cable exit: idler (60); pn 160022
		R	cable exit: RoundAbout™; pn 301224
	b	5	cable tension: -050
		6	cable tension: -060
		7	cable tension: -070
		8	cable tension: -080
	c	N	no sensor cover (60)
		S	sensor cover (60); pn 160060
	d	D	base: mounting disk (_6_); pn 160040-1 (cannot be ordered with a = R (cannot be used with RoundAbout™ cable exit))
		S	base: standard (60); pn 160015-1
		U	base: universal (60); pn 160030-1
		B	base: big foot (60/ 61); pn 160015-1
		H	base: h (60); pn 160015-G1
	P	base: universal (miniature) (60); pn 300460	

Series 161	a	S	cable exit: slot (61)
		C	cable exit: cable guide
		D	cable exit: idler (61/ 62); pn 161022
		R	cable exit: RoundAbout™; pn 301224
	b	5	cable tension: -050
		6	cable tension: -060
		7	cable tension: -070
		8	cable tension: -080
	c	N	no sensor cover (61)
		S	sensor cover (61); pn 160060
	d	D	base: mounting disk (_6_); pn 160040-1 (cannot be ordered with a = R (cannot be used with RoundAbout™ cable exit))
		S	base: standard (61); pn 160015-3
U		base: universal (61); pn 160030-3	
B		base: big foot (60/ 61); pn 160015-1	

Series 162	a	S	cable exit: slot (62)
		C	cable exit: cable guide
		D	cable exit: idler (61/ 62); pn 161022
		R	cable exit: RoundAbout™; pn 301224
	b	5	cable tension: -050
		6	cable tension: -060
		7	cable tension: -070
		8	cable tension: -080
	c	N	no sensor cover (62)
		S	sensor cover (62); pn 160060
	d	D	base: mounting disk (_6_); pn 160040-1 (cannot be ordered with a = R (cannot be used with RoundAbout™ cable exit))
		S	base: standard (62); pn 160015-
U		base: universal (62); pn 160030-	
B		base: big foot (62); pn 160015-1	

Displacement Cable Maximum Acceleration by Model Number

Model	Max Cable Acceleration (g's)			
	Opt 5: -.050 spring	Opt 6: -.060 spring	Opt 7: -.070 spring	Opt 8: -.080 spring
160-0161	10	19	35	46
160-0241	14	22	123	82
160-0321	8	10	23	69
160-0483	38	54	173	357
160-0643	43	55	147	427
160-0803	38	64	121	242
160-0963	30	42	103	182
160-1085	55	65	109	165
160-1285	42	47	99	105
160-1505	16	49	98	127
160-1705	30	40	75	70
161-0461	5	8	16	23
161-1283	-	38	76	126
161-1915	-	72	133	205
161-2145	-	70	130	201
161-2405	-	56	72	95
162-2735	-	-	60	84
162-2945	-	-	48	73
162-3205	-	-	37	63
162-3405	-	-	31	45

Drawing: shown with *slot cable exit*, standard base, and optional sensor cover.

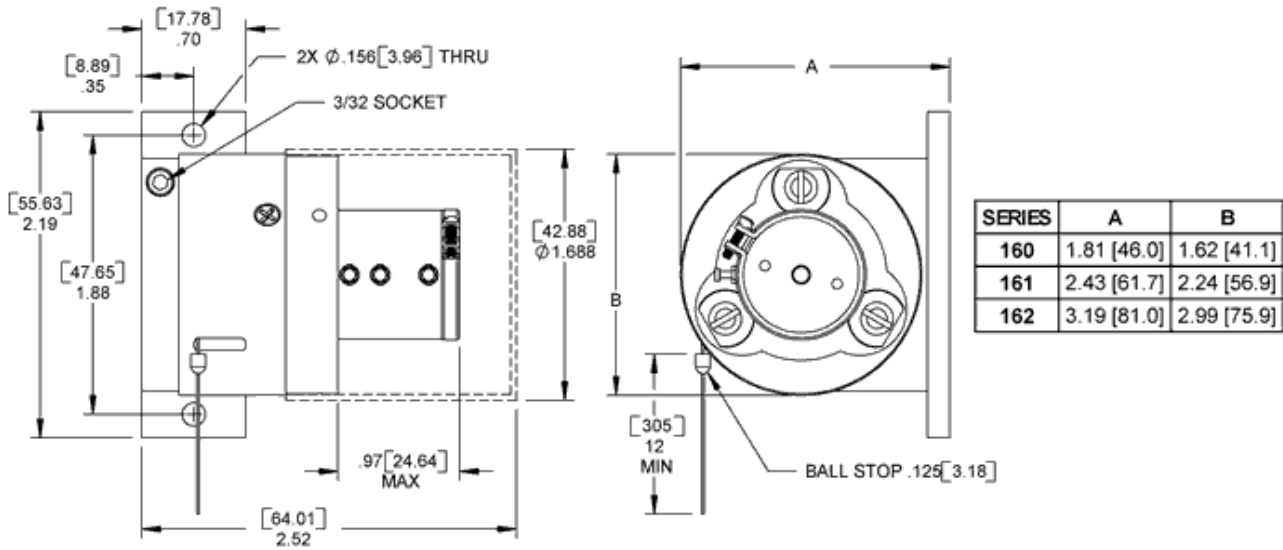

Drawing: shown with *cable guide cable exit*, standard base, and optional sensor cover.

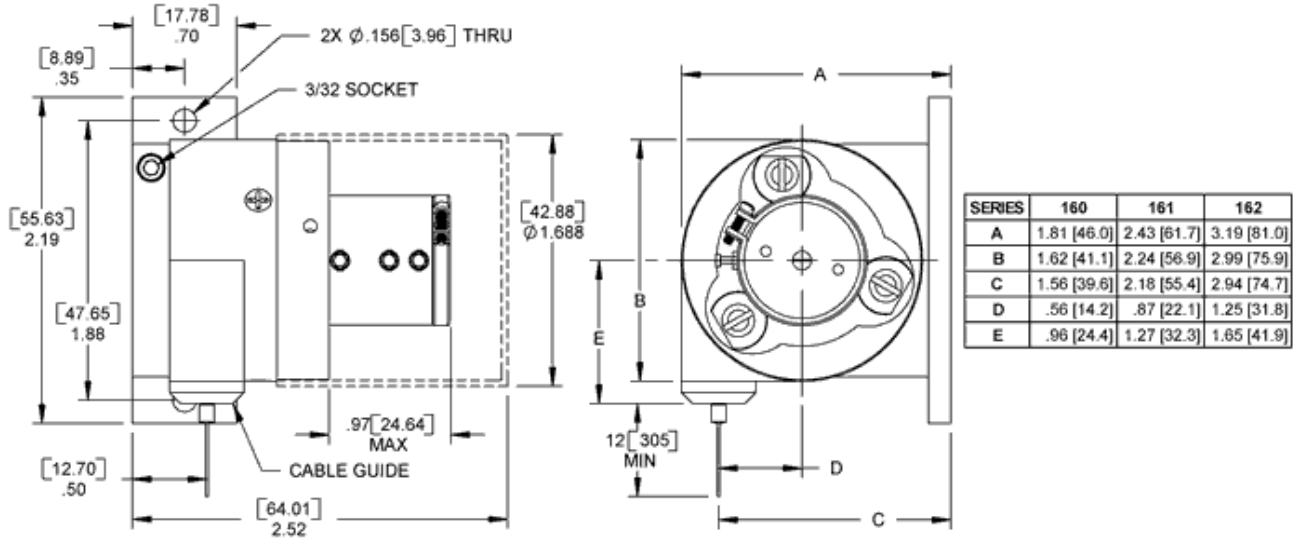

Drawing: shown with *idler cable exit*, standard base, and optional sensor cover.

Idler cable exit will reduce displacement cable life and may reduce maximum range by up to 0.75 inch (19.1 mm). Idler not recommended for use with -080 spring.

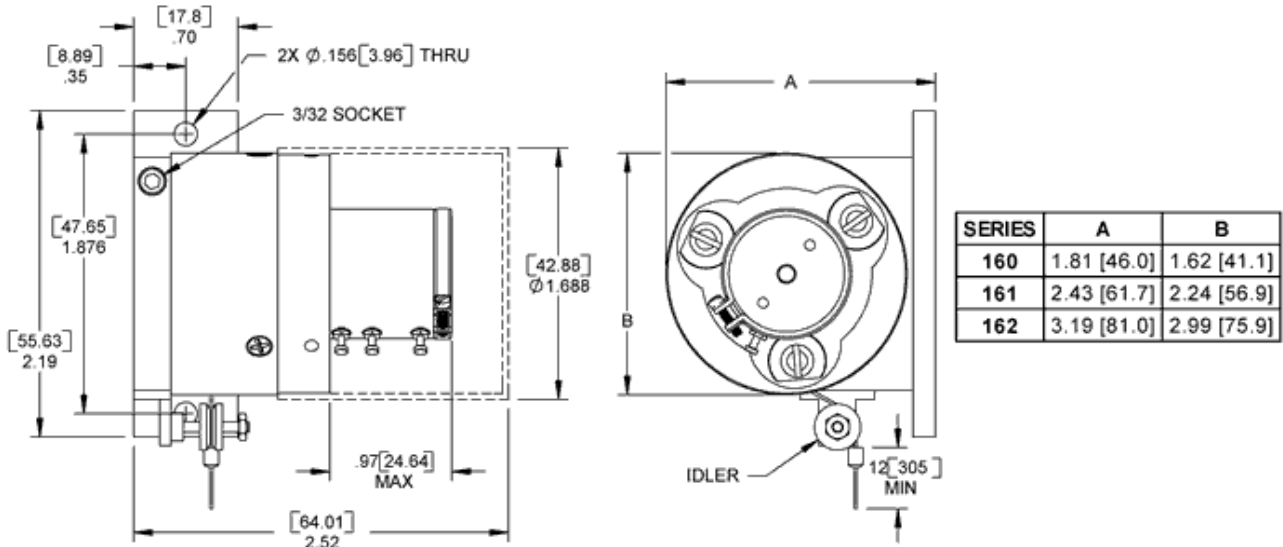

Drawing: RoundAbout™ cable guide dimensional details

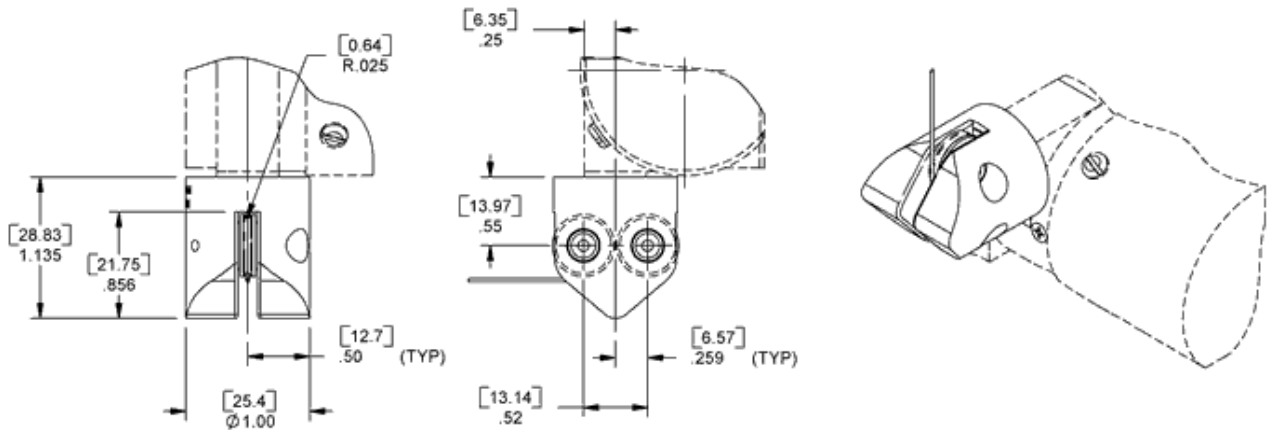

Electrical Schematic

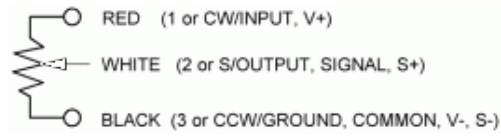

For crimping of hardware to displacement cable, consider the 160001-01 installation kit.

All dimensions are REFERENCE and are in inches [mm]