

FT Series Linear Actuators

Exlar FT Series force tube actuators use a planetary roller screw mounted inside a telescoping tube mechanism. The follower is attached to the moveable force tube, which then extends and retracts as the screw rotates. An external motor (supplied by Exlar or the customer) provides the rotational force.

High Performance

As with all of Exlar's roller screw products, the FT Series actuators deliver heavy load capacity, high speed capabilities, and exceptionally long life when compared to other linear actuator technologies.

Other comparably-sized screw actuator

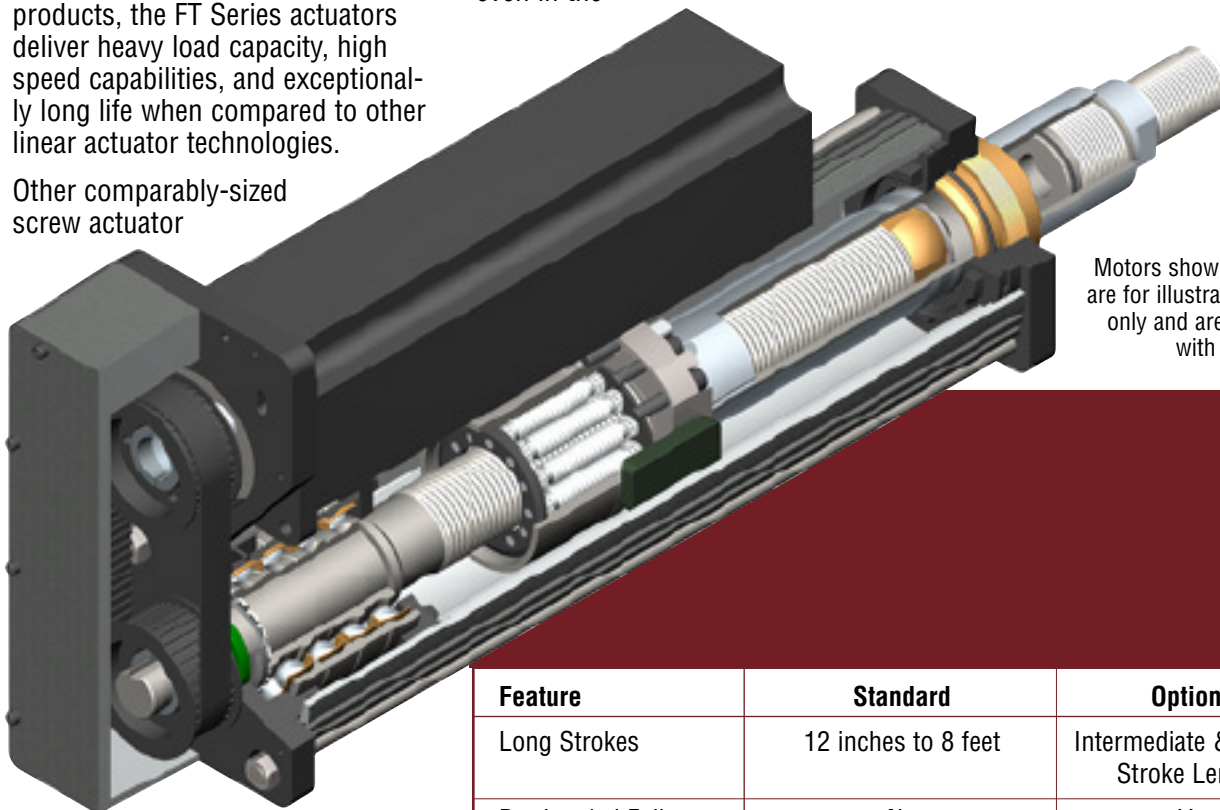

Motors shown in drawings are for illustrative purposes only and are not included with FT Actuators.

products on the market - specifically ball screw and acme screw actuators - have relatively low load capacities, short working lives and limited speed capabilities. At equivalent sizes, under moderate to heavy loads, it is reasonable to project that FT units will deliver up to 15 times the working life of those other designs. For OEM designers, this often means much more power and durability can be achieved from a

much smaller footprint when Exlar FT units are used.

Contamination Protection and Lifetime Lubrication

The FT Series design has all the contamination-isolation advantages of hydraulic cylinders without the limited load, life, and speed of designs built around ball or acme screws. The bearing and roller screw components in the Exlar FT Series force tubes are mounted within the sealed housing. This prevents abrasive particles and other contaminants from entering the actuator's critical mechanisms, and assures trouble-free operation even in the

most severe environments.

FT Series actuators are provided with standard grease lubrication. Custom provisions can be made for oil filled lubrication.

Engineered Compatibility

Exlar has removed much of the end-user-engineering burden by designing the FT series to be compatible with a wide variety of standard motors. Motor mounting, actuator mounting, and gearing configurations are available to meet nearly any application's requirements.

Feature	Standard	Optional
Long Strokes	12 inches to 8 feet	Intermediate & Custom Stroke Lengths
Pre-Loaded Follower	No	Yes
External End Switches	No	One, two or three Adjustable Switches
Multiple Actuator Mountings	Side Mount, Side Lug, Extended Tie Rods, Rear Clevis, Front Flange, Side Trunnion, Rear Flange, Front/Rear Flange	OEM Specials Available
Multiple Motor Mounting Configurations	Inline Direct Drive, Parallel 1:1 Drive, Parallel, 2:1 Reduction	OEM Specials Available

Special Sealing Options

The base unit of the FT actuators are sealed at the extending rod end by a rod seal, and on the drive end by a shaft seal (see base unit drawing on page 71). These rod and shaft seals, and o-ring sealing provides IP65 sealing for the FT actuator base units.

In standard units with inline, or parallel motor mounting, the mounting surface between the actuator and the motor, and between the end cover, or inline cover of the actuator and the actuator housing are not sealed as a standard feature.

These areas of the FT actuators can be sealed as a special option if

Stainless steel FT35 with stainless steel SLM115 motor

Food grade & stainless steel FT35 with food grade SLM90 motor

Food grade & stainless steel FT60 with food grade SLG90 motor

the environment in which the actuator will be mounted requires the actuator to be sealed. Because of the vast differences in the design of various brands of motors that are mounted to the FT Series actuators, sealing of these two areas

may alter the design of the actuator. Consult Exlar applications engineering for details and quotations on special sealing of this type.

EXLAR FT SERIES ACTUATORS APPLICATIONS INCLUDE:

Hydraulic cylinder replacement
Ball screw replacement
Pneumatic cylinder replacement
Chip and wafer handling
Automated flexible fixturing
Dispensers
Machine tool
Automated assembly
Parts clamping
Automatic tool changers
Volumetric pumps
Medical equipment

Conveyor diverters / gates
Plastics equipment
Cut-offs
Die cutters
Packaging machinery
Entertainment
Sawmill equipment
Open / close doors
Fillers
Formers
Precision grinders
Indexing stages

Lifts
Product sorting
Material cutting
Material handling
Riveting / fastening / joining
Molding
Volumetric pumps
Semiconductor
Pick and place systems
Robot manipulator arms
Simulators
Precision valve control

Ventilation control systems
Pressing
Process control
Tube bending
Welding
Stamping
Test stands
Tension control
Web guidance
Wire winding

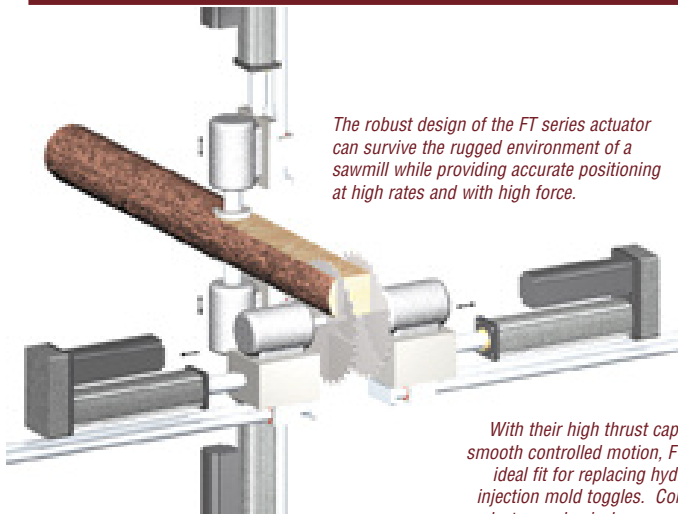

The robust design of the FT series actuator can survive the rugged environment of a sawmill while providing accurate positioning at high rates and with high force.

The smooth and accurate motion of Exlar's actuators combined with today's servo technology make multiple degree of freedom motion simulation applications easier to implement, cleaner and more efficient than hydraulic solutions.

With their high thrust capability, compact size and smooth controlled motion, FT Series actuators are an ideal fit for replacing hydraulics or pneumatics on injection mold toggles. Control improvements from an electromechanical servo system offer less abuse of valuable molds and more consistent performance.

Motors shown in drawings are for illustrative purposes only and are not included with FT Actuators.

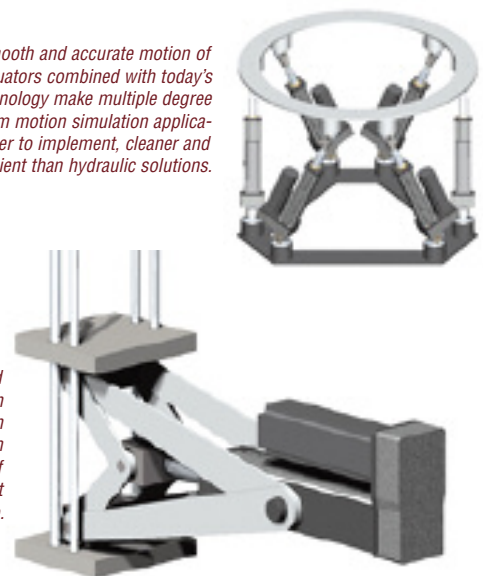

FT Series Lifetime Curves

The expected life of a force tube actuator is expressed as the travel distance that 90% of the actuators are expected to exceed before experiencing metal fatigue. The formula that defines this value is:

The underlying formula that defines this value is:

$$L_{10} = (C/F)^3 \times S \equiv \text{where}$$

- C = Dynamic load rating (lbs)
- F = Cubic mean applied load (lbs.)
- S = Roller screws lead (inches)

Travel life in millions of inches, where:

FT35

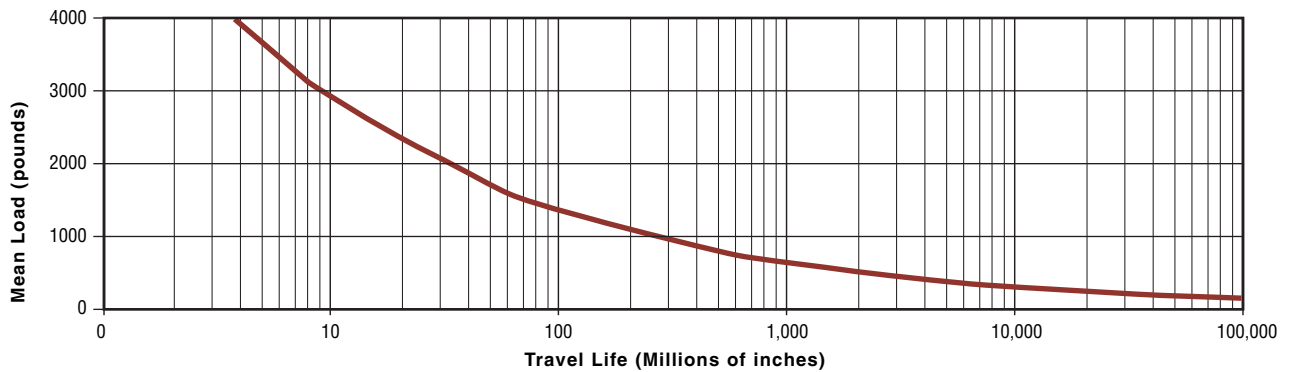

FT60

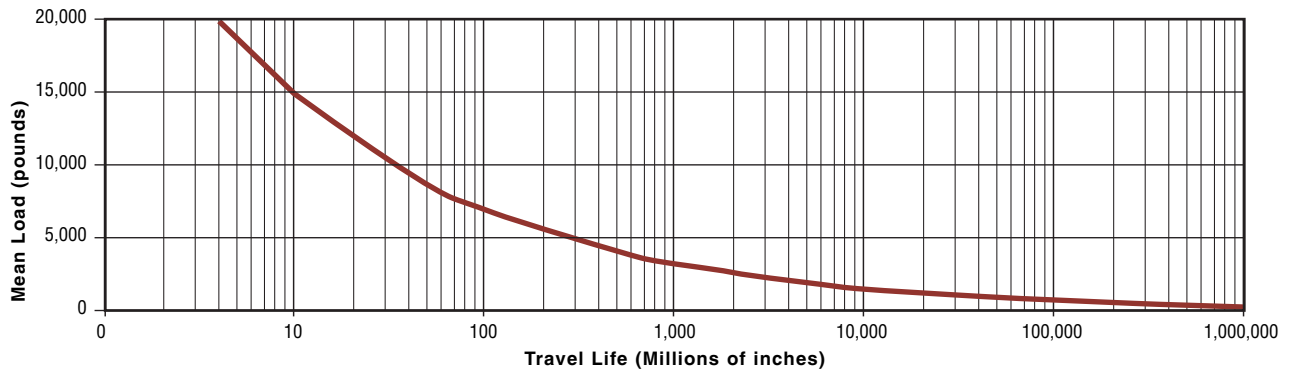

FT80

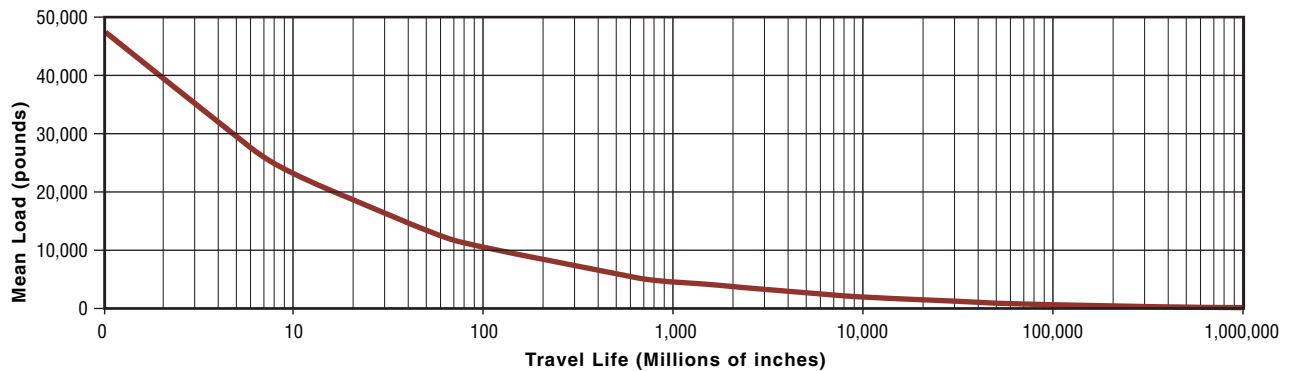

FT Series Performance Specifications

Model No.	Frame Size in (mm)	Stroke in (mm)	Screw Lead in (mm)	Max. Linear Speed in/sec (mm/sec)	Rated Force lbf (kN)	Dynamic Load Rating (std. follower) lbf (kN)	Torque @ Rated Force lb-in (N-m)	Screw Inertia lb-in-s ² (kg-m ²)	Max. Force* lbf (kN)	Max. Rot. Speed rpm	Weight Base Unit lb (kg)
FT35-0605	3.5 (89)	6 (152)	0.2 (5)	14.7 (373)	2000 (8.9)	10700 (47.5)	75 (8.3)	0.0019 (0.00022)	4000 (17.8)	4500	30 (14)
FT35-0610	3.5 (89)	6 (152)	0.39 (10)	29.5 (750)	2000 (8.9)	8700 (38.5)	150 (16.5)	0.0019 (0.00022)	4000 (17.8)	4500	30 (14)
FT35-0620	3.5 (89)	6 (152)	0.79 (20)	59.3 (1500)	2000 (8.9)	7100 (31.5)	300 (33.0)	0.0019 (0.00022)	4000 (17.8)	4500	30 (14)
FT35-1205	3.5 (89)	12 (304)	0.2 (5)	14.7 (373)	2000 (8.9)	10700 (47.5)	75 (8.3)	0.0027 (0.00031)	4000 (17.8)	4500	35 (16)
FT35-1210	3.5 (89)	12 (304)	0.39 (10)	29.5 (750)	2000 (8.9)	8700 (38.5)	150 (16.5)	0.0027 (0.00031)	4000 (17.8)	4500	35 (16)
FT35-1220	3.5 (89)	12 (304)	0.79 (20)	59.3 (1500)	2000 (8.9)	7100 (31.5)	300 (33.0)	0.0027 (0.00031)	4000 (17.8)	4500	35 (16)
FT35-1805	3.5 (89)	18 (457)	0.2 (5)	14.7 (373)	2000 (8.9)	10700 (47.5)	75 (8.3)	0.0037 (0.00042)	4000 (17.8)	4500	40 (18)
FT35-1810	3.5 (89)	18 (457)	0.39 (10)	29.5 (750)	2000 (8.9)	8700 (38.5)	150 (16.5)	0.0037 (0.00042)	4000 (17.8)	4500	40 (18)
FT35-1820	3.5 (89)	18 (457)	0.79 (20)	59.3 (1500)	2000 (8.9)	7100 (31.5)	300 (33.0)	0.0037 (0.00042)	4000 (17.8)	4500	40 (18)
FT35-2405	3.5 (89)	24 (610)	0.2 (5)	14.7 (373)	2000 (8.9)	10700 (47.5)	75 (8.3)	0.0045 (0.00051)	4000 (17.8)	4500	45 (21)
FT35-2410	3.5 (89)	24 (610)	0.39 (10)	29.5 (750)	2000 (8.9)	8700 (38.5)	150 (16.5)	0.0045 (0.00051)	4000 (17.8)	4500	45 (21)
FT35-2420	3.5 (89)	24 (610)	0.79 (20)	59.3 (1500)	2000 (8.9)	7100 (31.5)	300 (33.0)	0.0045 (0.00051)	4000 (17.8)	4500	45 (21)
FT35-3605	3.5 (89)	36 (914)	0.2 (5)	8.9 (226)	2000 (8.9)	10700 (47.5)	75 (8.3)	0.0061 (0.00069)	4000 (17.8)	2700	55 (25)
FT35-3610	3.5 (89)	36 (914)	0.39 (10)	17.8 (452)	2000 (8.9)	8700 (38.5)	150 (16.5)	0.0061 (0.00069)	4000 (17.8)	2700	55 (25)
FT35-3620	3.5 (89)	36 (914)	0.79 (20)	35.6 (903)	2000 (8.9)	7100 (31.5)	300 (33.0)	0.0061 (0.00069)	4000 (17.8)	2700	55 (25)
FT35-4805	3.5 (89)	48 (1219)	0.2 (5)	5.7 (145)	2000 (8.9)	10700 (47.5)	75 (8.3)	0.0076 (0.00086)	4000 (17.8)	1700	65 (30)
FT35-4810	3.5 (89)	48 (1219)	0.39 (10)	11.4 (290)	2000 (8.9)	8700 (38.5)	150 (16.5)	0.0076 (0.00086)	4000 (17.8)	1700	65 (30)
FT35-4820	3.5 (89)	48 (1219)	0.79 (20)	22.4 (568)	2000 (8.9)	7100 (31.5)	300 (33.0)	0.0076 (0.00086)	4000 (17.8)	1700	65 (30)

Intermediate and custom stroke lengths are available. Intermediate leads may also be available. Belt and pulley inertia varies with ratio & motor selection. Contact Exlar's Applications Engineering Department for more information. See page 70 for definition of terms.

* The rated and max force on the FT series actuators are those forces derived from using typical servo motors of similar frame size to the actuator, at their rated continuous and peak torques. In many cases FT actuators can be configured with input sufficient to exceed these forces. Contact Exlar for further details.

FT Standard Inline Coupling Maximum Torque Ratings and Inertia

	Torque Rating	Inertia
FT35	40N-m (354 lbf-in)	0.30 lb-in, 0.000777 lbf-in-sec ²

Pulley inertias lbf X in X sec², reflected at motor including typical pulleys, belt and standard bushings. Because of differences in belt and pulley selection due to particular motor choices, please contact Exlar's Application Engineering Department if these values are critical to your application.

FT35 3 inch motor 1:1 = 0.004874 FT35 4 inch motor 1:1 = 0.009993
 FT35 3 inch motor 2:1 = 0.002087 FT35 3 inch motor 2:1 = 0.005003

EXLAR
FT Series Linear Actuators

FT Series Performance Specifications

Model No.	Frame Size in (mm)	Stroke in (mm)	Screw Lead in (mm)	Max. Linear Speed in/sec (mm/sec)	Rated Force lbf (kN)	Dynamic Load Rating (std. follower) lbf (kN)	Torque @ Rated Force lb-in (N-m)	Screw Inertia lb-in-s ² (kg-m ²)	Max. Force* lbf (kN)	Max. Rot. Speed rpm	Weight Base Unit lb (kg)
FT60-1206	6.0 (152)	12 (305)	0.23 (6)	7.9 (201)	10,000 (45.4)	51900 (231)	460 (50.6)	0.0454 (0.0051)	20,000 (90.8)	2000	100 (45)
FT60-1212	6.0 (152)	12 (305)	0.47 (12)	15.8 (401)	10,000 (45.4)	44600 (199)	860 (94.6)	0.0454 (0.0051)	20,000 (90.8)	2000	100 (45)
FT60-1230	6.0 (152)	12 (305)	1.18 (30)	39.0 (1000)	10,000 (45.4)	41700 (186)	2200 (242)	0.0454 (0.0051)	20,000 (90.8)	2000	100 (45)
FT60-2406	6.0 (152)	24 (610)	0.23 (6)	7.9 (201)	10,000 (45.4)	51900 (231)	460 (50.6)	0.073 (0.0083)	20,000 (90.8)	2000	130 (59)
FT60-2412	6.0 (152)	24 (610)	0.47 (12)	15.8 (401)	10,000 (45.4)	44600 (199)	860 (94.6)	0.073 (0.0083)	20,000 (90.8)	2000	130 (59)
FT60-2430	6.0 (152)	24 (610)	1.18 (30)	39.0 (1000)	10,000 (45.4)	41700 (186)	2200 (242)	0.073 (0.0083)	20,000 (90.8)	2000	130 (59)
FT60-3606	6.0 (152)	36 (914)	0.23 (6)	7.9 (201)	10,000 (45.4)	51900 (231)	460 (50.6)	0.1 (0.0113)	20,000 (90.8)	2000	160 (72)
FT60-3612	6.0 (152)	36 (914)	0.47 (12)	15.8 (401)	10,000 (45.4)	44600 (199)	860 (94.6)	0.1 (0.0113)	20,000 (90.8)	2000	160 (72)
FT60-3630	6.0 (152)	36 (914)	1.18 (30)	39.0 (1000)	10,000 (45.4)	41700 (186)	2200 (242)	0.1 (0.0113)	20,000 (90.8)	2000	160 (72)
FT60-4806	6.0 (152)	48 (1219)	0.23 (6)	7.9 (201)	10,000 (45.4)	51900 (231)	460 (50.6)	0.126 (0.0142)	20,000 (90.8)	2000	190 (86)
FT60-4812	6.0 (152)	48 (1219)	0.47 (12)	15.8 (401)	10,000 (45.4)	44600 (199)	860 (94.6)	0.126 (0.0142)	20,000 (90.8)	2000	190 (86)
FT60-4830	6.0 (152)	48 (1219)	1.18 (30)	39.0 (1000)	10,000 (45.4)	41700 (186)	2200 (242)	0.126 (0.0142)	20,000 (90.8)	2000	190 (86)

Intermediate and custom stroke lengths are also available. Intermediate leads may also be available. Belt and pulley inertia varies with ratio and motor selection. See page 70 for definitions of terms.

* The rated and max force on the FT series actuators are those forces derived from using typical servo motors of similar frame size to the actuator, at their rated continuous and peak torques. In many cases FT actuators can be configured with input sufficient to exceed these forces. Contact Exlar for further details.

Ft Standard Inline Coupling Maximum Torque Ratings and Inertia

	Torque Rating	Inertia
FT60	100N-m (885 lbf-in)	0.90 lb-in, 0.002331 lbf-in-sec ²

Pulley inertias lbf X in X sec², reflected at motor including typical pulleys, belt and standard bushings. Because of differences in belt and pulley selection due to particular motor choices, please contact Exlar's Application Engineering Department if these values are critical to your application.

FT60 1:1 = 0.030000

FT60 2:1 = 0.035000

FT Series Performance Specifications

Model No.	Frame Size in (mm)	Stroke in (mm)	Screw Lead in (mm)	Max. Linear Speed in/sec (mm/sec)	Rated Force lbf (kN)	Dynamic Load Rating (std. follower) lbf (kN)	Torque @ Rated Force lb-in (N-m)	Screw Inertia lb-in-s ² (kg-m ²)	Max. Force* lbf (kN)	Max. Rot. Speed rpm	Weight Base Unit lb (kg)
FT80-1206	8.0 (203)	12 (305)	0.23 (6)	6.9 (175)	20,000 (90.8)	80700 (358)	975 (107)	0.1630 (0.0184)	40,000 (178)	1750	190 (86)
FT80-1212	8.0 (203)	12 (305)	0.47 (12)	13.8 (351)	20,000 (90.8)	70200 (312)	1775 (195)	0.1630 (0.0184)	40,000 (178)	1750	190 (86)
FT80-1230	8.0 (203)	12 (305)	1.18 (30)	34.4 (875)	20,000 (90.8)	64700 (288)	4420 (485)	0.1630 (0.0184)	40,000 (178)	1750	190 (86)
FT80-2406	8.0 (203)	24 (610)	0.23 (6)	6.9 (175)	20,000 (90.8)	80700 (358)	975 (107)	0.247 (0.0279)	40,000 (178)	1750	265 (120)
FT80-2412	8.0 (203)	24 (610)	0.47 (12)	13.8 (351)	20,000 (90.8)	70200 (312)	1775 (195)	0.247 (0.0279)	40,000 (178)	1750	265 (120)
FT80-2430	8.0 (203)	24 (610)	1.18 (30)	34.4 (875)	20,000 (90.8)	64700 (288)	4420 (485)	0.247 (0.0279)	40,000 (178)	1750	265 (120)
FT80-3606	8.0 (203)	36 (914)	0.23 (6)	6.9 (175)	20,000 (90.8)	80700 (358)	975 (107)	0.331 (0.0374)	40,000 (178)	1750	340 (153)
FT80-3612	8.0 (203)	36 (914)	0.47 (12)	13.8 (351)	20,000 (90.8)	70200 (312)	1775 (195)	0.331 (0.0374)	40,000 (178)	1750	340 (153)
FT80-3630	8.0 (203)	36 (914)	1.18 (30)	34.4 (875)	20,000 (90.8)	64700 (288)	4420 (485)	0.331 (0.0374)	40,000 (178)	1750	340 (153)
FT80-4806	8.0 (203)	48 (1219)	0.23 (6)	6.9 (175)	20,000 (90.8)	80700 (358)	975 (107)	0.415 (0.0468)	40,000 (178)	1750	415 (187)
FT80-4812	8.0 (203)	48 (1219)	0.47 (12)	13.8 (351)	20,000 (90.8)	70200 (312)	1775 (195)	0.415 (0.0468)	40,000 (178)	1750	415 (187)
FT80-4830	8.0 (203)	48 (1219)	1.18 (30)	34.4 (875)	20,000 (90.8)	64700 (288)	4420 (485)	0.415 (0.0468)	40,000 (178)	1750	415 (187)

Intermediate and custom stroke lengths are also available. Intermediate leads may also be available. Belt and pulley inertia varies with ratio and motor selection. Please contact Exlar's Applications Engineering Department for more information.

* The rated and max force on the FT series actuators are those forces derived from using typical servo motors of similar frame size to the actuator, at their rated continuous and peak torques. In many cases FT actuators can be configured with input sufficient to exceed these forces. Contact Exlar for further details.

FT Standard Inline Coupling Maximum Torque Ratings and Inertia

	Torque Rating	Inertia
FT80	200N-m (1770 lbf-in)	3.89 lb-in, 0.010075 lbf-in-sec ²

Pulley inertias lbf X in X sec², reflected at motor including typical pulleys, belt and standard bushings. Because of differences in belt and pulley selection due to particular motor choices, please contact Exlar's Application Engineering Department if these values are critical to your application.

FT80 1:1 = 0.235000

FT80 2:1 = 0.157000

Definitions:

Max Linear Speed: The linear speed achieved by the actuator at a screw speed equal to the max rotational speed value.

Rated Force: The linear force produced by the actuator at the torque at the rated force value.

Dynamic Load Rating: A design constant used in calculating the estimated travel life of the roller screw. The dynamic mean load is the mean load at which the device will perform one million revolutions.

Torque At Rated Force: The torque required at the screw to produce the force rating.

Screw Inertia: The rotary inertia of the planetary roller screw in the actuator.

Max. Rot. Speed: The maximum allowable rotational screw speed determined by the screw length or the rotational speed limit of the roller screw nut.

FT Series Mechanical Specifications

		FT35	FT60	FT80
Roller Screw Backlash	in (mm)	0.0004 - 0.001 (0.01 - 0.03)	0.0004 - 0.001 (0.01 - 0.03)	0.0004 - 0.001 (0.01 - 0.03)
Preloaded Loader Screw Backlash		0	0	0
System Backlash:*	in (mm)	0.002 (0.006)	0.002 (0.006)	0.002 (0.006)
Standard Lead Accuracy:**	in/ft (mm/mm)	0.001 (.025/300)	0.001 (.025/300)	0.001 (.025/300)
Maximum Radial Load		0	0	0
Environmental Rating: (Base Unit Only)***	Standard	IP65	IP65	IP65
Case:	Standard Optional	Epoxy-coated aluminum Food Grade Coating	Epoxy-coated aluminum Food Grade Coating	Epoxy-coated aluminum Food Grade Coating

* System backlash will be different with various types of motor mounting arrangements and couplings. Please discuss your particular configuration with Exlar application engineers.
 ** Optional lead accuracy – from 0.0002 in/ft (6µm/300mm) to 0.002 in/ft (200µm/1000mm) – are also available.
 *** For IP65 scaling of unit with motor mounted, please contact Exlar's Applications Engineering Department for more information and ordering information.

FT Linear Actuator Base Unit

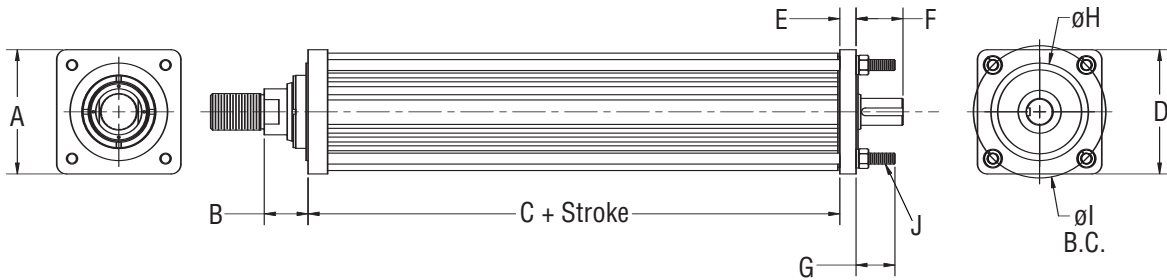

	A	B	C	D	E	F	G	øH	øI
FT35	3.625 (92.1)	1.690 (42.9)	9.125 (231.8)	3.625 (92.1)	0.570 (14.5)	2.126 (54.0)	1.500 (38.1)	3.00 (76.2)	3.860 (98.0)
FT60	6.375 (161.9)	2.249 (57.1)	15.287 (388.3)	6.375 (161.9)	0.830 (21.1)	2.409 (61.2)	2.000 (50.8)	5.000 (127.0)	6.788 (172.4)
FT80	8.500 (215.9)	3.033 (77.0)	19.812 (503.2)	8.500 (215.9)	0.900 (22.9)	3.355 (85.2)	3.00 (76.2)	6.750 (171.5)	9.330 (237.0)
	J	K	øL	M	N	O			
FT35	3/8-16	0.236 ^{-0.0005} _{-0.0017}	0.750 ^{+0.0000} _{-0.0005}	0.138 ^{+0.004} _{-0.000}	1.890				
	UNC-2A	6.00mm (p9)	19.05mm ^{+0.000} _{-0.013}	3.50mm ^{+0.10} _{-0.00}	(48mm)	0.100			
FT60	9/16-12	0.394 ^{-0.0006} _{-0.0020}	1.379 ^{+0.0000} _{-0.0005}	0.197 ^{-0.008} _{-0.000}	2.126				
	UNC-2A	10.00mm (p9)	35.00mm ^{+0.000} _{-0.013}	5.00mm ^{+0.20} _{-0.00}	(54mm)	0.100			
FT80	3/4-10	0.709 ^{-0.0007} _{-0.0024}	2.362 ^{+0.0000} _{-0.0005}	0.295 ^{+0.005} _{-0.000}	2.559				
	UNC-2A	18.00mm (p9)	60mm ^{-0.000} _{-0.013}	7.5mm ^{+0.13} _{-0.00}	(65mm)	0.150			

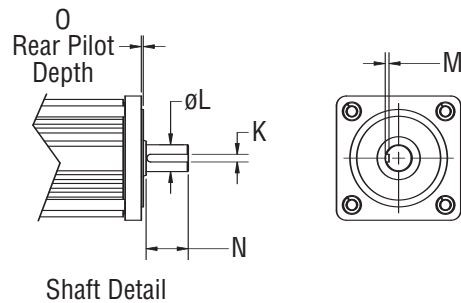

All dimensions in inches unless otherwise noted.
 See rod ends drawing for rod end details.

FT Linear Actuator Clevis Mount

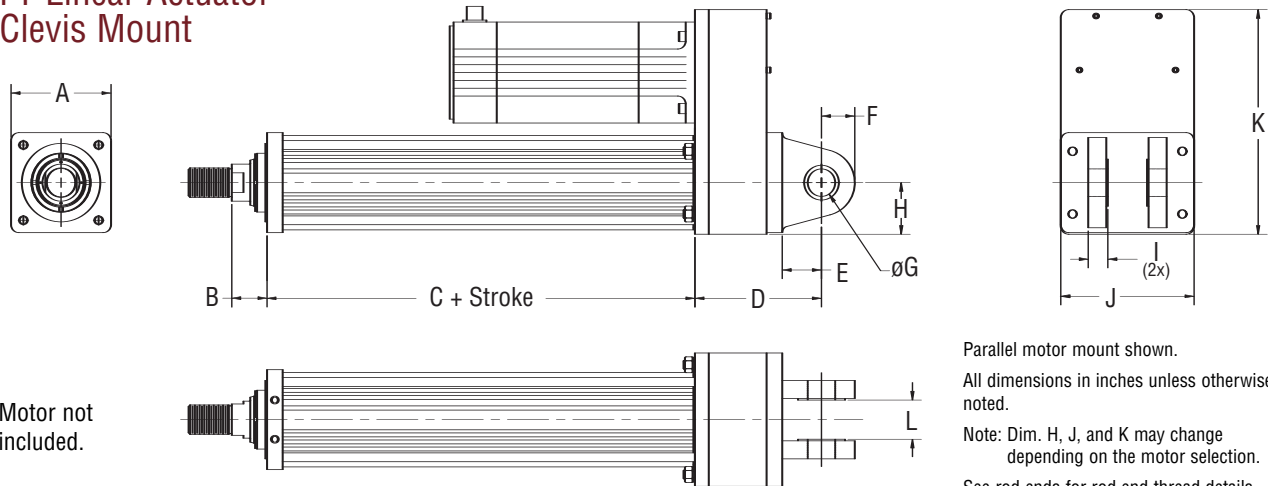

	A	B	C	D	E	F	øG	H	I	J	K	L
FT35	3.625 (92.1)	1.690 (42.9)	9.125 (231.8)	6.250 (158.8)	1.500 (38.1)	1.000 (25.4)	1.001 ^{+0.000} _{-.001} (25.43 ^{+0.000} _{-.025})	1.960 (49.8)	0.747 (19.0)	5.250 (133.4)	9.600 (243.8)	1.507 (38.3)
FT60	6.375 (161.9)	2.249 (57.1)	15.287 (388.3)	8.070 (205.1)	2.500 (63.5)	2.125 (54.0)	1.753 ^{+0.000} _{-.001} (44.53 ^{+0.000} _{-.025})	3.290 (83.6)	1.250 (31.8)	8.500 (215.9)	14.320 (363.7)	2.500 (63.5)
FT80	8.500 (215.9)	3.033 (77.0)	19.812 (503.2)	N/A N/A	N/A N/A	N/A N/A	N/A N/A	N/A N/A	N/A N/A	N/A N/A	N/A N/A	N/A N/A

FT Linear Actuator Side Mount

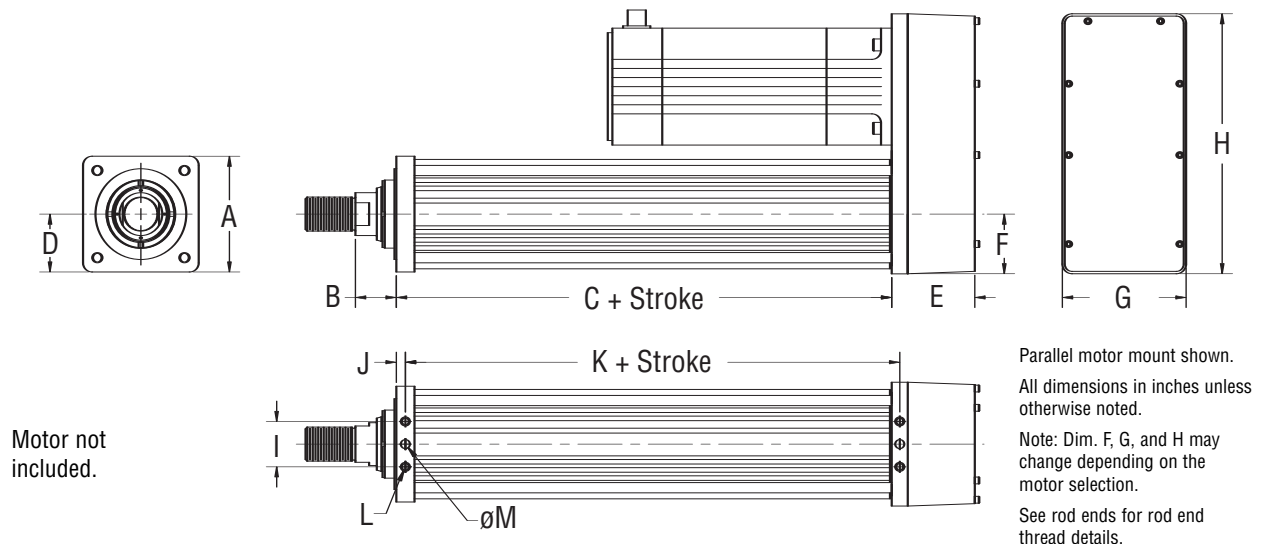

	A	B	C	D	E	F	G	H	I	J	K	L	øM
FT35	3.625 (92.1)	1.690 (42.9)	9.125 (231.8)	1.813 (46.1)	4.185 (106.3)	1.813 (46.1)	5.250 (133.4)	9.600 (243.8)	1.625 (41.3)	0.312 (7.9)	9.123 (231.7)	1/4-20 UNC-2B x 0.625	N/A
FT60	6.375 (161.9)	2.249 (57.1)	15.287 (388.3)	3.188 (81.0)	4.570 (116.1)	3.188 (81.0)	6.875 (174.6)	14.320 (363.7)	2.500 (63.5)	0.500 (12.7)	15.227 (386.8)	1/2-13 UNC-2B x 1.125	N/A
FT80	8.500 (215.9)	3.033 (77.0)	19.812 (503.2)	4.250 (108.0)	6.440 (163.6)	4.250 (108.0)	8.780 (223.0)	17.340 (440.4)	4.000 (101.6)	0.750 (19.1)	19.563 (496.9)	5/8-11 UNC-2B x 1.250	0.625 x 1.375

Drawings subject to change. Consult Exlar for certified drawings.

FT Linear Actuator Side Lug Mount

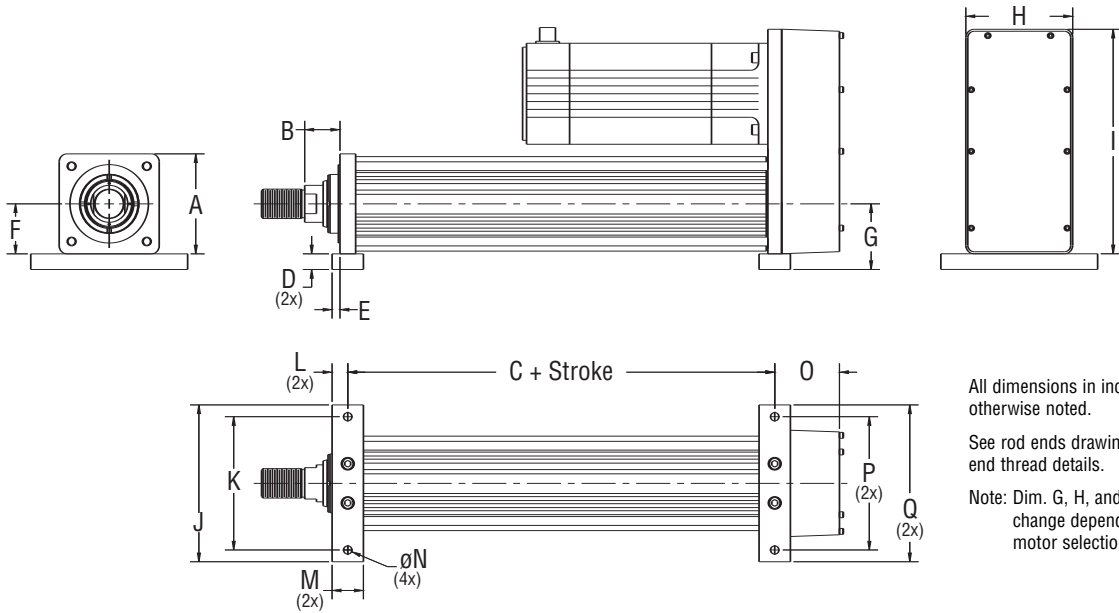

All dimensions in inches unless otherwise noted.
 See rod ends drawing for rod end thread details.
 Note: Dim. G, H, and I may change depending on the motor selection.

	A	B	C	D	E	F	G	H	I	J	K	L	M	ϕN	O	P	Q
FT35	3.625 (92.1)	1.690 (42.9)	9.123 (231.7)	0.750 (19.1)	0.188 (4.8)	1.813 (46.1)	2.563 (65.1)	5.250 (133.4)	9.453 (240.1)	6.250 (158.8)	5.250 (133.4)	0.500 (12.7)	1.000 (25.4)	0.406 (10.3)	3.875 (98.4)	6.500 (165.1)	7.500 (190.5)
FT60	6.375 (161.9)	2.249 (57.1)	15.227 (386.8)	1.000 (25.4)	0.500 (12.7)	3.188 (81.0)	4.188 (106.4)	6.875 (174.6)	14.218 (361.1)	10.000 (254.0)	8.500 (215.9)	1.000 (25.4)	2.000 (50.8)	0.531 (13.5)	4.130 (104.9)	8.500 (215.9)	10.000 (254.0)
FT80	8.500 (215.9)	3.033 (77.0)	19.563 (496.9)	2.000 (50.8)	0.500 (12.7)	4.250 (108.0)	6.250 (158.8)	8.780 (223.0)	17.170 (436.1)	12.750 (323.9)	10.750 (273.1)	1.250 (31.8)	2.500 (63.5)	0.781 (19.8)	5.940 (150.9)	10.750 (273.1)	12.750 (323.9)

Drawings subject to change. Consult Exlar for certified drawings.

FT Linear Actuator Front Flange Mount

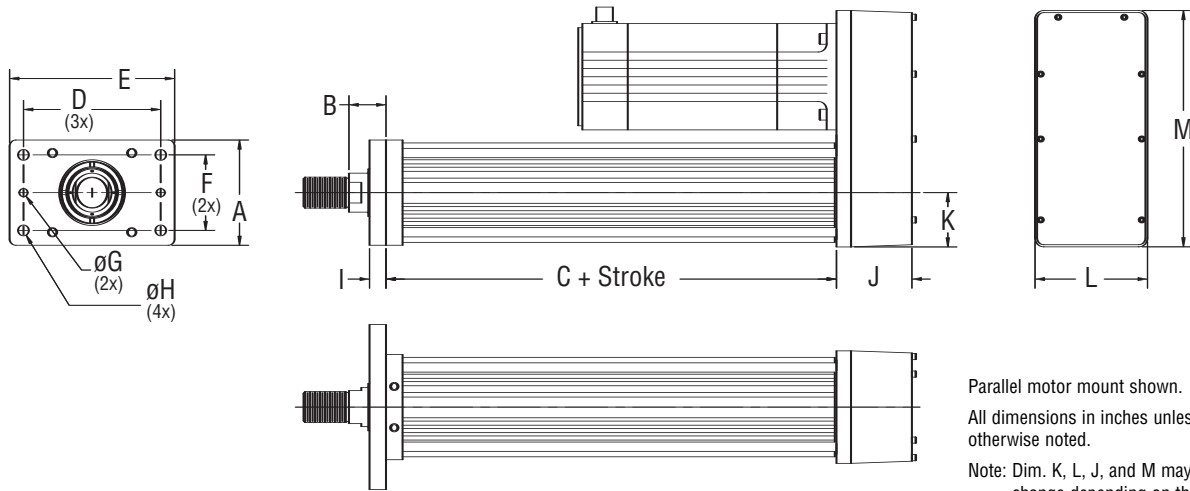

Parallel motor mount shown.
 All dimensions in inches unless otherwise noted.
 Note: Dim. K, L, J, and M may change depending on the motor selection.
 See rod ends for rod end thread details.

	A	B	C	D	E	F	øG	øH	I	J	K	L	M
FT35	3.625 (92.1)	1.690 (42.9)	9.125 (231.8)	4.750 (120.7)	5.750 (146.1)	2.500 (63.5)	0.375 ^{+0.000} _{-0.001} (9.53 ^{+0.000} _{-0.025})	0.530 (13.5)	0.625 (15.9)	4.185 (106.3)	1.960 (49.8)	5.250 (133.4)	9.600 (243.8)
FT60	6.375 (161.9)	2.249 (57.1)	15.287 (388.3)	8.315 (211.2)	10.000 (254.0)	4.575 (116.2)	0.501 ^{+0.000} _{-0.001} (12.73 ^{+0.000} _{-0.025})	0.656 (16.7)	1.000 (25.4)	4.570 (116.1)	3.290 (83.6)	6.875 (174.6)	14.320 (363.7)
FT80	8.500 (215.9)	3.033 (77.0)	19.812 (503.2)	10.750 (273.1)	12.750 (323.9)	6.000 (152.4)	0.625 ^{+0.000} _{-0.001} (15.88 ^{+0.000} _{-0.025})	0.781 (19.8)	1.250 (31.8)	6.440 (163.6)	4.420 (112.3)	8.780 (223.0)	17.340 (440.4)

Drawings subject to change. Consult Exlar for certified drawings.

FT Linear Actuator Rear Flange Mount

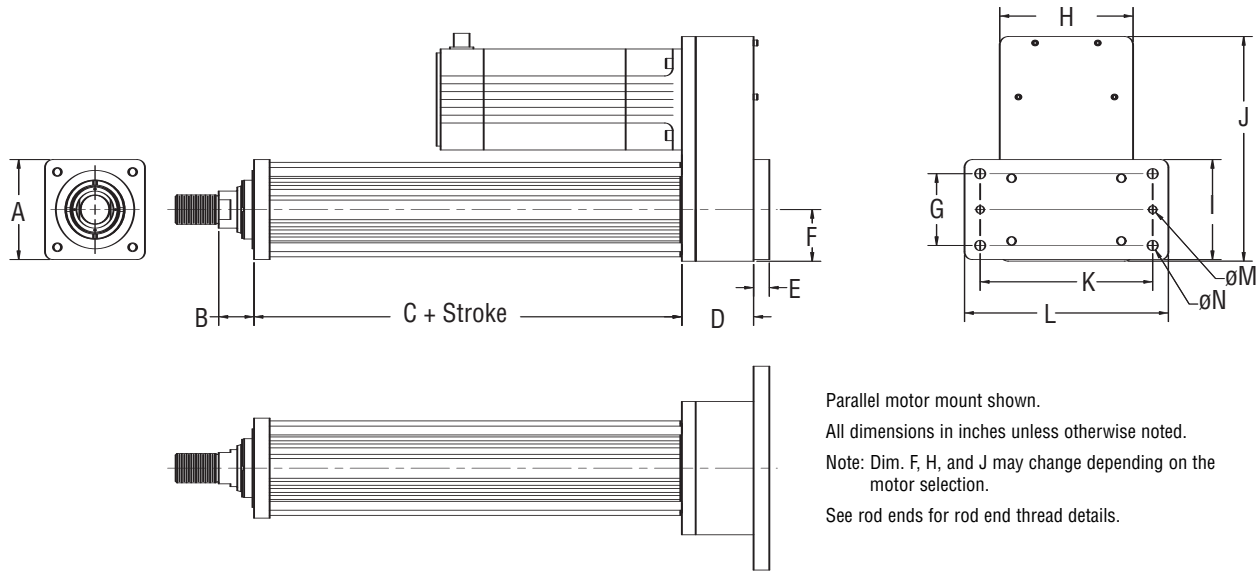

	A	B	C	D	E	F	G	H	I	J	K	L	øM	øN
FT35	3.625 (92.1)	1.690 (42.9)	9.125 (231.8)	4.125 (104.8)	0.625 (15.9)	1.960 (49.8)	2.500 (63.5)	5.250 (133.4)	3.500 (88.9)	9.600 (243.8)	6.500 (165.1)	7.500 (190.5)	N/A (N/A)	0.530 (13.5)
FT60	6.375 (161.9)	2.249 (57.1)	15.287 (388.3)	4.570 (116.1)	1.000 (25.4)	3.290 (83.6)	4.575 (116.2)	8.500 (215.9)	6.375 (161.9)	14.320 (363.2)	11.000 (279.4)	13.000 (330.2)	0.501 (12.7)	0.656 (16.7)
FT80	8.500 (215.9)	3.033 (77.0)	19.812 (503.2)	N/A N/A	N/A N/A	N/A N/A	N/A N/A	N/A N/A	N/A N/A	N/A N/A	N/A N/A	N/A N/A	N/A N/A	N/A N/A

Drawings subject to change. Consult Exlar for certified drawings.

FT Linear Actuator Extended Tie Rod Mount

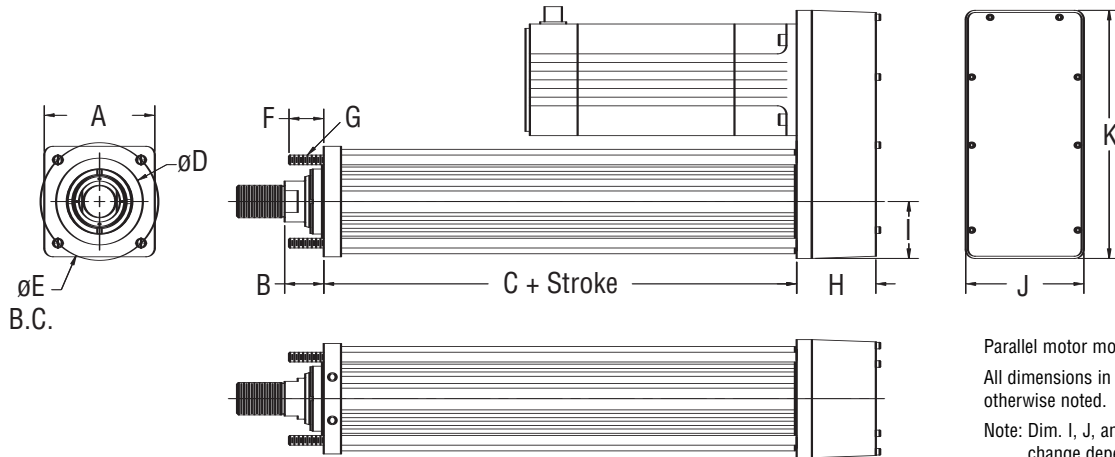

Parallel motor mount shown.
 All dimensions in inches unless otherwise noted.
 Note: Dim. I, J, and K may change depending on the motor selection.
 See rod ends for rod end thread details.

	A	B	C	øD	øE	F	G	H	I	J	K
FT35	3.625 (92.1)	1.690 (42.9)	9.125 (231.8)	3.000 ^{+0.000} / _{-.002} (76.2 ^{+0.000} / _{-.051})	3.859 (98.0)	1.250 (31.8)	3/8-16 UNC-2A	4.185 (106.3)	1.960 (49.8)	5.250 (133.4)	9.600 (243.8)
FT60	6.375 (161.9)	2.249 (57.1)	15.287 (388.3)	5.000 ^{+0.000} / _{-.002} (127.0 ^{+0.000} / _{-.051})	6.788 (172.4)	2.000 (50.8)	9/16-12 UNC-2A	4.570 (116.1)	3.290 (83.6)	6.875 (174.6)	14.320 (363.7)
FT80	8.500 (215.9)	3.033 (77.0)	19.812 (503.2)	6.750 ^{+0.000} / _{-.002} (171.5 ^{+0.000} / _{-.051})	9.330 (237.0)	3.500 (88.9)	3/4-10 UNC-2A	6.440 (163.6)	4.420 (112.3)	8.780 (223.0)	17.340 (440.4)

Drawings subject to change. Consult Exlar for certified drawings.

FT Linear Actuator Standard Trunnion Mount

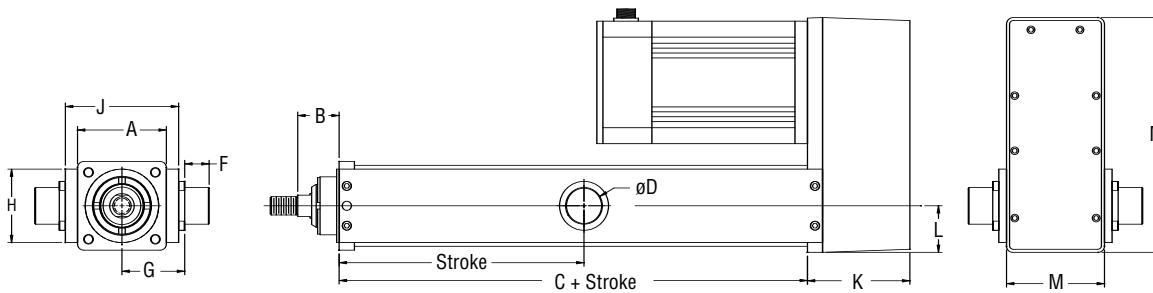

Parallel Motor Mount Shown

Note: Dimensions K, L, M, & N may change depending on motor/drive ratio selection.

Trunnion mount available on FT35 up to 48" stroke length; FT60 up to 36" stroke length; FT80 consult Exlar.

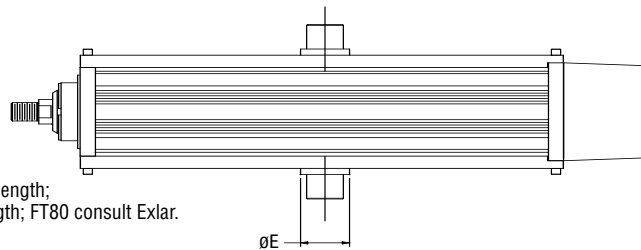

	A	B	C	D	E	F	G	H	J	K	L	M	N
FT35	3.63 (92.1)	1.09 (42.9)	9.12 (231.7)	1.500 (38.1)	2.00 (50.8)	1.00 (25.4)	2.66 (85.1)	3.00 (76.2)	4.63 (117.5)	4.19 (108.3)	1.96 (49.8)	6.25 (133.4)	9.60 (243.8)
FT60	6.38 (161.9)	2.25 (57.1)	15.23 (386.8)	2.500 (63.5)	3.50 (88.9)	2.00 (50.8)	4.06 (103.2)	5.00 (127.0)	7.88 (200.0)	4.57 (116.1)	3.29 (83.6)	6.88 (174.6)	14.32 (363.7)
FT80	Contact Exlar												

FT Linear Actuator Rod End

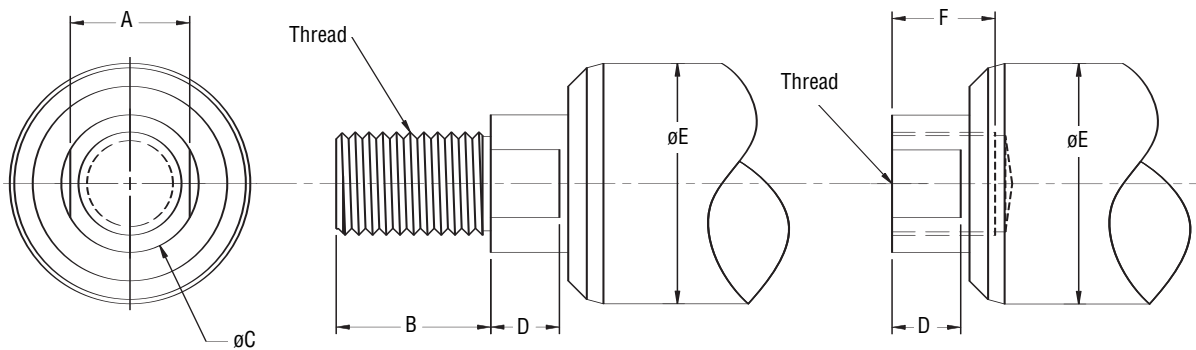

	A	B	øC	D	øE	F	Male U.S.	Male Metric	Female U.S.	Female Metric
FT35	0.87 (22.1)	1.125 (28.6)	1.000 (25.4)	0.500 (12.7)	1.750 (44.5)	0.750 (19.1)	3/4-16 UNF-2A	M16X1.5	3/4-16 UNF-2B	M16X1.5
FT60	2.00 (50.8)	2.750 (69.9)	2.360 (59.9)	0.750 (19.1)	3.000 (76.2)	2.000 (50.8)	1 7/8-12 UN-2A	M42X4.5	1 7/8-12 UN-2B	M42X4.5
FT80	2.75 (69.9)	4.019 (102.1)	3.143 (79.8)	1.000 (25.4)	4.000 (101.6)	2.250 (57.2)	2 1/2-12 UN-2A	M56X5.5	2 1/2-12 UN-2B	M56X5.5

Drawings subject to change. Consult Exlar for certified drawings.

<p>FT Series Ordering Information</p>	<div style="display: flex; justify-content: center; gap: 10px;"> <div style="border: 1px solid black; padding: 2px 5px;">FTAA</div> - <div style="border: 1px solid black; padding: 2px 5px;">BB</div> - <div style="border: 1px solid black; padding: 2px 5px;">CC</div> - <div style="border: 1px solid black; padding: 2px 5px;">D</div> - <div style="border: 1px solid black; padding: 2px 5px;">E</div> - <div style="border: 1px solid black; padding: 2px 5px;">F</div> - <div style="border: 1px solid black; padding: 2px 5px;">GGG</div> - <div style="border: 1px solid black; padding: 2px 5px;">XX XX</div> </div>
<p>AA = FT Frame Size 35 = 3.5 inch frame actuator 60 = 6.0 inch frame actuator 80 = 8.0 inch frame actuator</p>	<p>GGG = Motor Mount Provisions* (Please indicate the motor that will be used with the FT Actuator by it's 3 digit code.) NMT = No motor mount – keyed shaft on base unit only N34 = NEMA 34 motor mount N42 = NEMA 42 motor mount N56 = NEMA 56 motor mount AB3,4,6,8 = Allen Bradley Ultra 3, 4, 6, & 8 inch motors BD3,4,6,8 = Baldor 3, 4, 6, & 8 inch motors CE3,4,6,8 = Parker(Custom Servo Motors) Imperial 3, 4, 6, & 8 inch motors CM3,4,6,8 = Parker(Custom Servo Motors) Metric 3, 4, 6, & 8 inch motors EE3,4 = Emerson EMC Imperial 3 & 4 inch English motors EM3,4,6,8 = Emerson EMC Metric 3, 4, 6, & 8 inch Metric motors EC3,4,6,8 = ElectroCraft F&H 3000, 4000, 6000 series, 8000 Series FA 4,6,8 = Fanuc 4, 6 & 8 inch motors IN3,4,6,8 = Bosch- Rexroth (Indramat) 3, 4, 6, & 8 inch motors KM2,4,6,8 = Kollmorgen B & M 20, 40, 60, & 80 Series MT3,4,6,8 = Mitsubishi 3,4,6 & 8 inch motors PS3,4,6,8 = Pacific Scientific PMA/PMB Series PC2,3,4,6 = Parker Compumotor Apex 2.7, 3.6, 4.5, & 5.6 inch YS3,4,6,8 = Yaskawa 3, 4, 6, & 8 inch motors MXX = Unlisted or special motor mounting provisions</p>
<p>BB = Stroke Length 06 = 6 inch (FT35) 12 = 12 inch (FT35, 60, 80) 18 = 18 inch (FT35) 24 = 24 inch (FT35, 60, 80) 36 = 36 inch (FT35, 60, 80) 48 = 48 inch (FT35, 60, 80)</p>	
<p>CC = Lead 05 = 0.2 inch (FT35) 06 = 0.23 inch (FT60, 80) 10 = 0.39 inch (FT35) 12 = 0.47 inch (FT60, 80) 20 = 0.79 inch (FT35) 30 = 1.18 inch (FT60, 80)</p>	
<p>D = Mounting Style S = Side mount L = Side lugs E = Extended tie rods C = Rear clevis (NA w/inline) F = Front flange T = Side trunnion mount (not available on all sizes and lengths) R = Rear flange (not available with inline motor mount) B = Front / rear flange (not available with inline motor mount) X = Special</p>	<p>XX .. XX = Options Housing Options XH = Special housing options XT = Special travel SS = Stainless steel FG = Food grade white epoxy (IP65 sealing of unit with motor mounted require “XH” option.)</p>
<p>E = Motor Mounting Configurations N = None I = Inline direct drive (includes Exlar standard coupling) P = Parallel, 1:1 drive Q = Parallel, 2:1 reduction X = Special</p>	<p>Special Follower PF = Preloaded follower. The dynamic load rating of zero backlash, preloaded screws is 63% of the dynamic load rating of the standard non-preloaded screws. The calculated travel life of a preloaded screw will be 25% of the calculated travel life of the same size and lead non-preloaded screw for the same application. FX = Special follower</p>
<p>F = Rod End M = Male, U.S. standard F = Female, U.S. standard A = Male, metric B = Female, metric X = Special Consult Factory for female ends.</p>	<p>End Switches (adjustable position throughout stroke) L1 = One adjustable switch, (10-30 VDC, PNP, N.C., 1m. 3 wire embedded cable) L2 = Two adjustable switches, (10-30 VDC, PNP, N.C., 1m. 3 wire embedded cable) L3 = Three adjustable switches, (10-30 VDC, PNP, N.C., 1m. 3 wire embedded cable)</p> <p>Please provide a drawing of motor dimensions with all orders to insure proper mounting compatibility.</p> <p>*Mounting face size, shaft length and other details of particular motors may require special adapters or provisions for mounting. Always discuss your motor selection with Exlar engineering.</p>

Consult Exlar's Application Engineering Department regarding all special actuator components.