



## Our Valued Customers

- Andritz Hydro Pvt. Ltd.
- Alstom Projects India Ltd.
- Abam Offshore Ltd.
- ABB Ltd.
- BOSCH Rexroth India Ltd.
- BHEL
- Cape Comorin Wind Corporation
- Elecon Engineering Company Ltd.
- Genting Lanco Power (India) Pvt. Ltd.
- Heinzmann India Pvt. Ltd.
- Jaiprakash Power Ventures Ltd.
- Kerala State Electricity Board
- Maharashtra State Power Generation Company Ltd.
- National Hydro Power Corporation Ltd.
- Nathpa Jhakri Power Station
- NHDC Ltd.
- Siemens Ltd.
- Satluj Jal Vidyut Nigam Ltd.
- The TATA Power Company Ltd.
- Turbo Tech Precision Engineering
- United Spirits
- Voith Hydro Pvt. Ltd.
- Vallibel Power Company Erathne Ltd.
- Wipro Infrastructure Engineering

COMBUSTION CONTROL  
GEOMETRY CONTROL  
GUIDE VANE CONTROL  
LIQUID/ GAS FUEL CONTROL  
PITCH BLADE CONTROL  
RUNNER BLADE CONTROL  
STEAM CONTROL

# POWERGEN

*Your Best Partner*

**SERVOCONTROLS & Hydraulics (I) Pvt. Ltd.**

Website : [www.servocontrolsindia.com](http://www.servocontrolsindia.com)

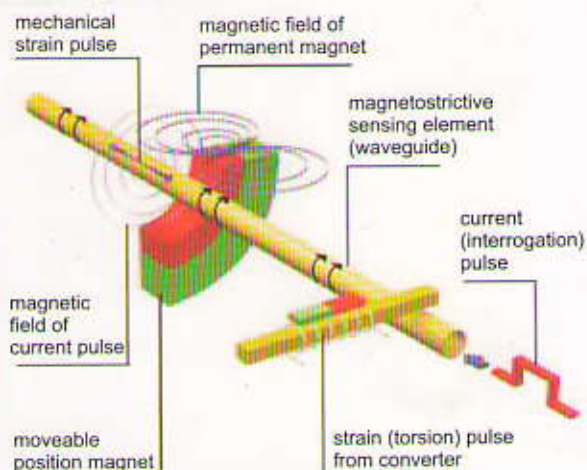
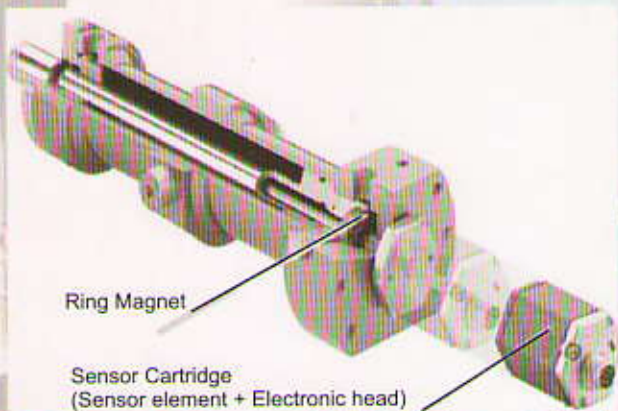

## MTS Temposonic Position Sensors for Gas Turbine, Hydal Turbine, Steam Turbine, Wind Turbine GH & RH Series

**TEMPOSONICS-RP+RH**  
SSI

**TEMPOSONICS-GP+GH**  
Analog + Start/Stop

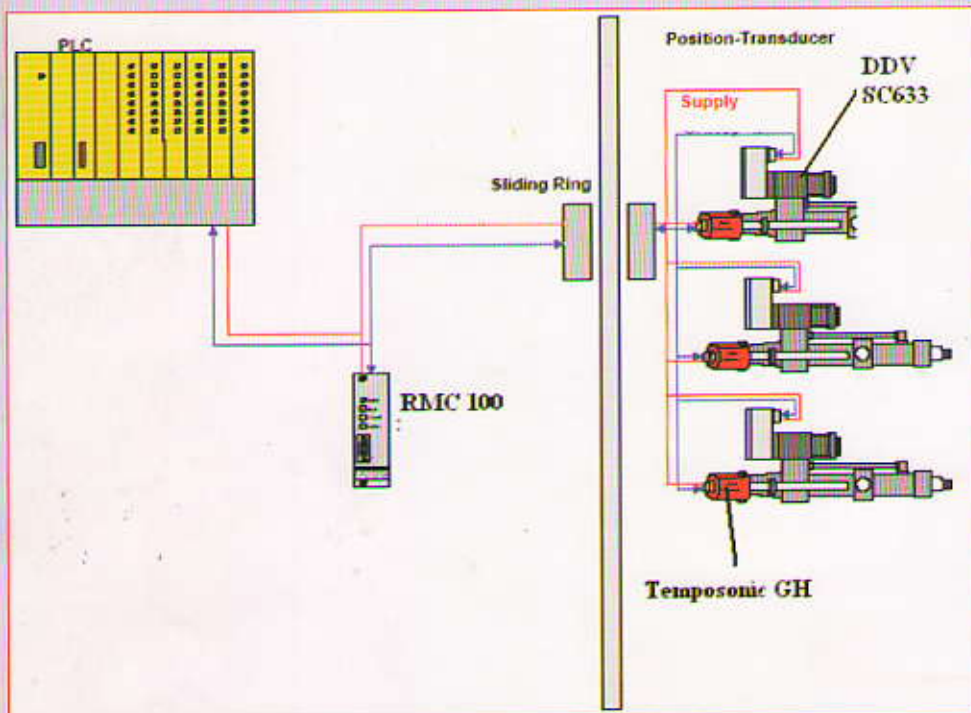

One of the first applications of direct drive valve was the pitch control of the blade of a wind turbine. The pitch of the blade is adjusted to the wind speed to optimize efficiency of wind turbine. The challenge of this application is that the pitch control and including the valve rotate together with rotor of the turbine.

### Application : PITCH BLADE CONTROL FOR WIND TURBINE

Benefits :

- ◆ Superior response and accuracy result in higher Turbine performance.
- ◆ Accuracy also results in higher consistency from change over to change over as well as reduced setup time
- ◆ Rugged, reliable construction allows for use in wide range of environmentally harsh conditions.
- ◆ Superior EMI and noise immunity ensures trouble free operation in a wide variety of applications.
- ◆ Fail safe Servovalves when electronics failure takes place.

### Inhouse Facilities

- Inhouse Mechanical/Electronics/Electrical Design Departments.
- State of the Art 2/3/5 axes machine shop
- Clean Room facility for Hydraulics and Electromechanical systems
- Electronic lab with software development center
- Assembly and Test Shop
- Fabrication and Paint Shop
- Metrology Lab
- Servo Lab



### Quality Control/Inspection Room with CMM & Contour



### Anti - Static Electronics Lab with Highly Trained Engineers



## APPLICATION

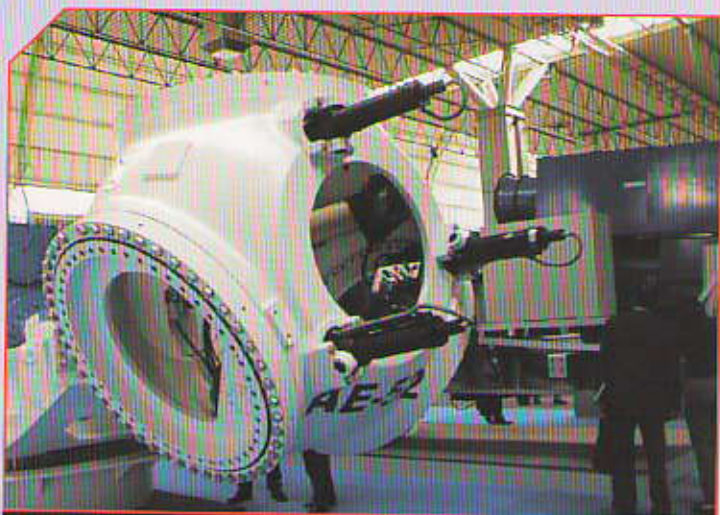

ROTOR OF THE WIND TURBINE WITH BLADE PITCH CONTROL AXIS

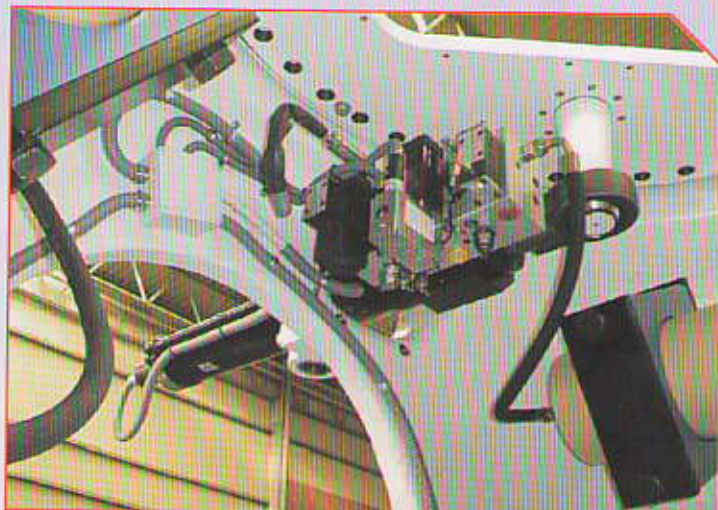

PITCH CONTROL AXIS WITH DDV ( DIRECT DRIVE VALVE)

### PRODUCTS USED

- DIRECT DRIVE VALVE (SC 633)
- MANIFOLD BLOCKS
- TEMPOSONIC RH & GH SERIES

STALL CONTROL : FIXED SPEED  
: Electric Yaw Control

ACTIVE STALL : VARIABLE SPEED +  
FIXED SPEED  
: Electric Yaw Control  
: Electric Pitch Control  
: Hydraulic Pitch Control

PITCH CONTROL : VARIABLE SPEED:  
: Electric Yaw Control  
: Electric Pitch Control  
: Hydraulic Pitch Control

## APPLICATION

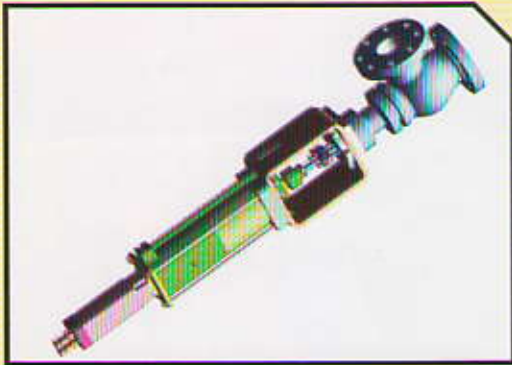

**SERVO CONTROLS - EXLAR ELECTRO  
MECHANICAL ACTUATORS FOR PRECISION  
POSITION OF VALVES & DAMPERS.**

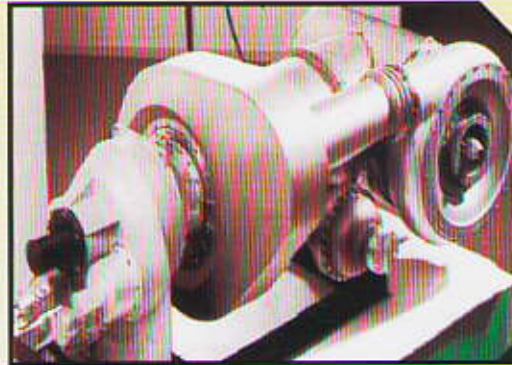

**MICRO TURBINE**

**PRODUCTS USED**

**DDV (SC 633)**

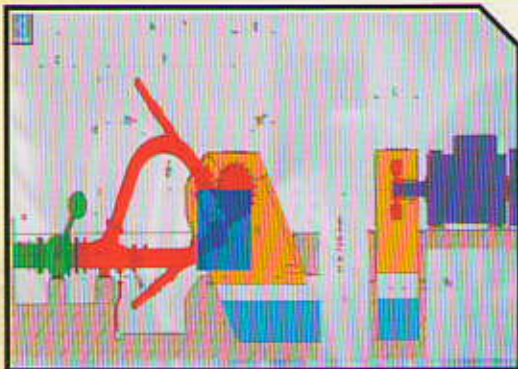

**WATER TURBINE**

**PRODUCTS USED**

**DDV (SC 633)**

**TEMPOSONIC SENSOR ( RH & GH )**

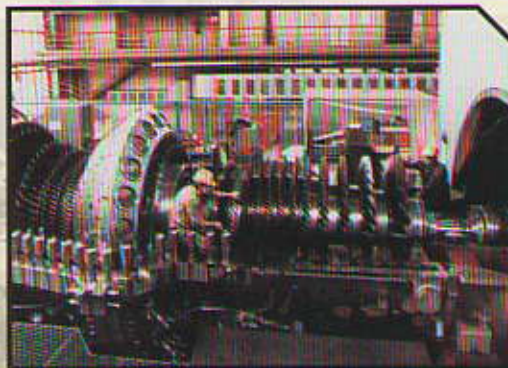

**GAS TURBINE**

**G.E. Gas Turbine  
Intrinsically Safe  
Servovalves**

**A55 200 - 001**

**A55 201 - 001**

**A55 202 - 001**

**A55 203 - 001**



**STEAM TURBINE**

**PRODUCTS USED**

**DDV (SC 633)**

**Servo valves (890 Series)**

# Product Mix & Applications



- **Servocontrol**
- **Critical Applications :**
  - Liquid Fuel Control
  - Gas Fuel Control
  - Steam Control
  - Geometry Control
  - Combustion Control
- **Forward-Integration**
  - Servovalve
  - Servoactuator
  - Integrated Fuel / Process Valve

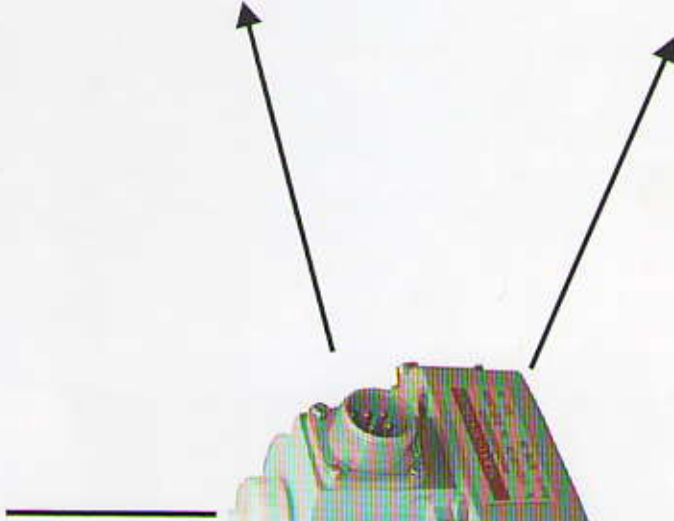
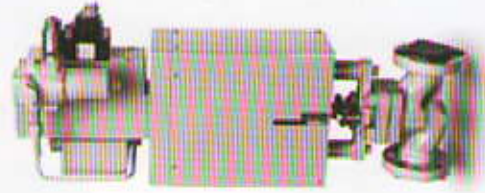
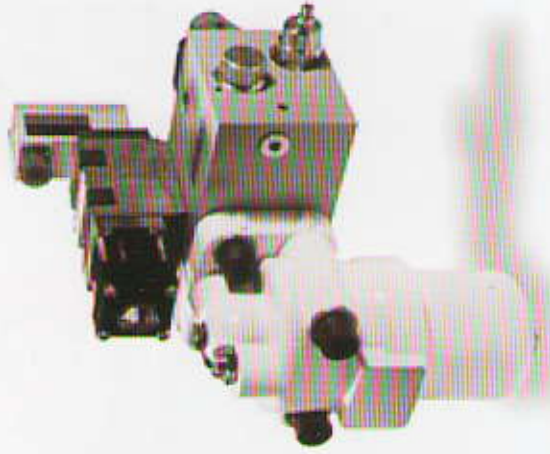

SERVOCONTROLS  
SERVOCONTROLS  
SERVOCONTROLS

### Manifold Block for CCW Butterfly Valve

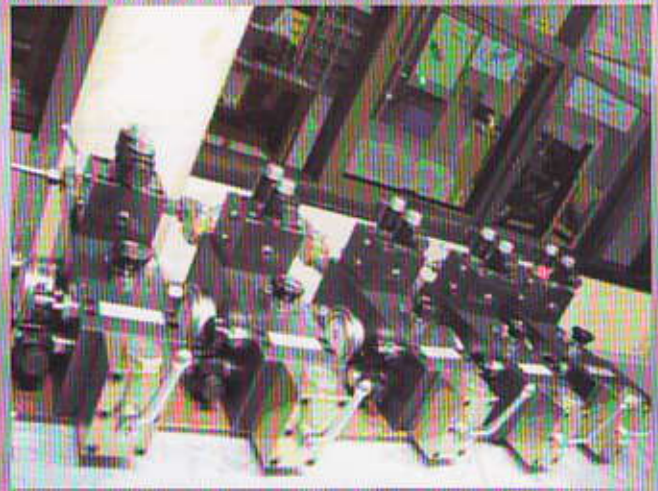
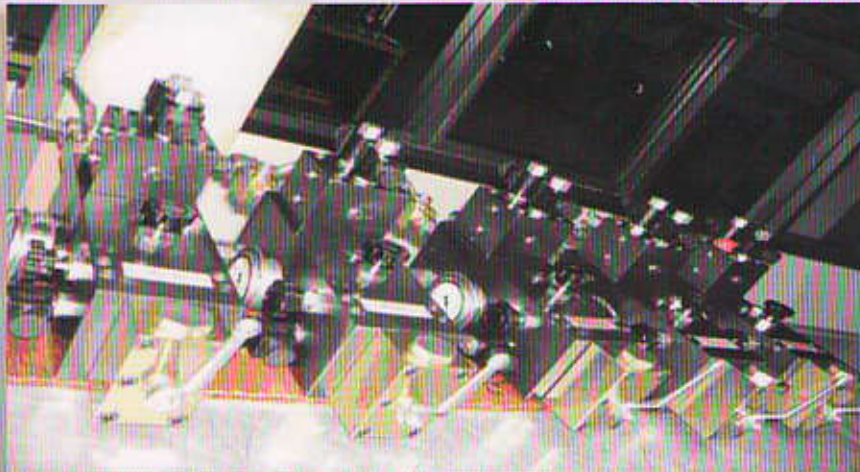

Designed and developed for steam turbine (Maharashtra State Power Generation Company Ltd.) Chandrapur

We build 1:1 replacement manifold block system, hydraulic power packs and electronics for existing / old steam or hydel turbines. (MRO) Maintenance, Repairs and Operations of Gas Turbines / Steam Turbines / Hydel Turbine, Actuation system.



### **SERVOCONTROLS Actuators used in Steam Turbine as Governor Valve**

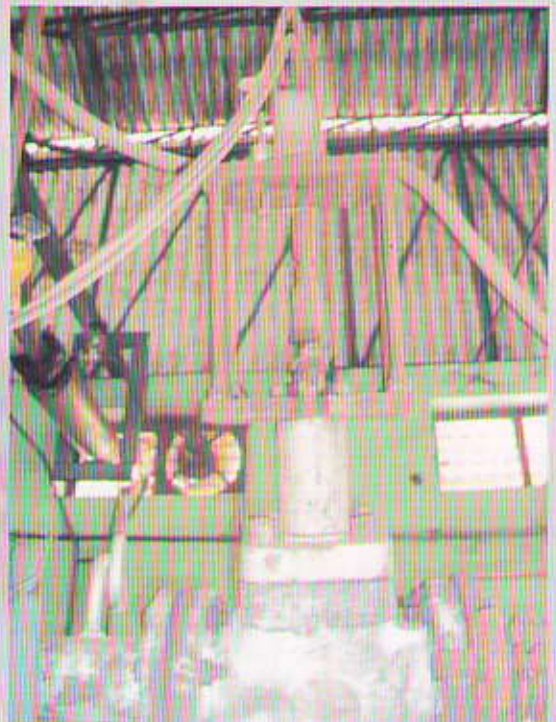
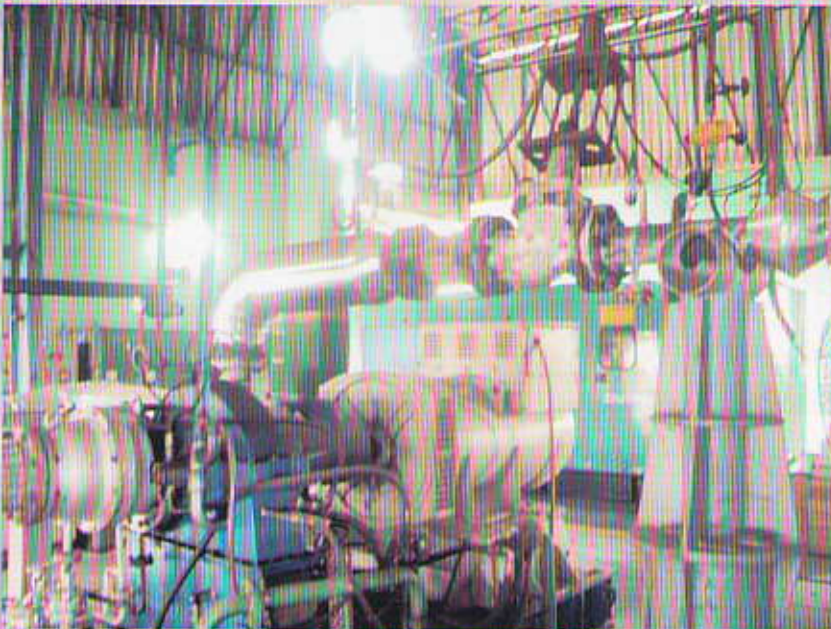

Servocontrol Linear Actuator used for governor valve to control the speed of turbine.

Servocontrol Linear Actuator is developed and used in United Spirits (UB Groups) Hospet

Servocontrols GSM 30 series actuator are used in steam condensing turbine and back pressure turbine.

500 KWatt to 1.5 MWatt

Turbine RPM controlled from 1500 to 12,000 RPM

Actuator Lead Accuracy = 0.001 inch/ feet

Actuator Force = 1600 N to 55109 N

Actuator Velocity = 8.33 inch/ sec. to 20 inch/sec.

Actuator input supply = 110 VAC/ 230 VAC/ 400 VAC/ 460 VAC 3 phase

Actuator Mounting Options = Front Flange, Extended tie rod,  
(Special as per custom requirements available)



## SERVOCONTROLS - EXLAR ELECTROMECHANICAL ACTUATORS

At Servocontrols - Exlar, we are very proud of our innovation and development of quality products. With our unique product offering, we have pushed the limits of conventional motion control to provide more speed and more force with less space and less maintenance. Our core competency is our patented roller screw technology which differentiates us from every other actuators supplier. Now we have expanded our competency to rotary motors and gear motors. This product breadth, combined with solid engineering and product quality allowed us to succeed in our business. We have assembled an extensive support network of highly trained professionals and earned the confidence of our customers. Servocontrols - Exlars unique products could be incorporated into your design for more efficient motion control. We would welcome the opportunity to discuss your motion requirements, specially where you don't want oil and want to replace hydraulic cylinders.

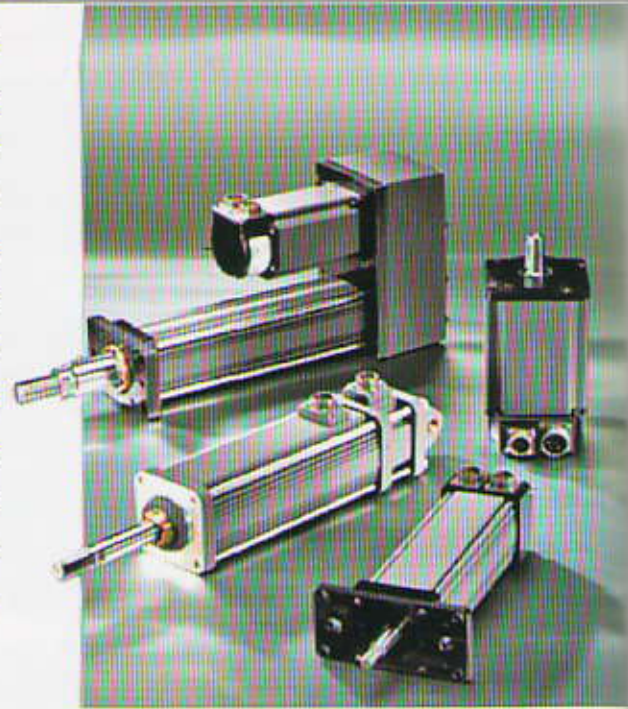

### Roller Screw Advantages

Roller screw design provides high speeds, stiffness and shock load resistance and **"Is having 15 times more life than Ball Screw technology actuators."**

- ◆ Large static loads up to 35.0 M Tonnes.
- ◆ High screw speeds - 5000 rpm and above.
- ◆ Up to 15 times longer life. Ideally suited for heavy duty turbine applications.
- ◆ Preloaded nut options for zero backlash.

### Unique Design

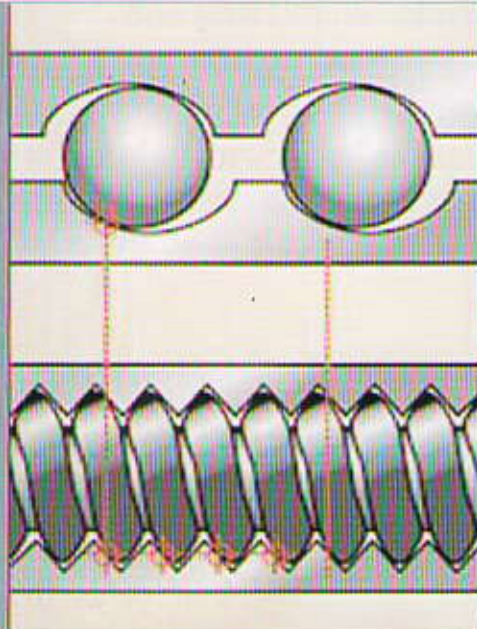

This robust roller screw design is composed of rollers that are manufactured with precisely the same thread angle as the nut. This construction is particularly well suited to applications that require very high loads and high speeds. This is possible because Servocontrols - Exlars planetary roller screw designs provide many more contact points than possible on comparably sized ball screws. This result in higher stiffness, higher load capacity and 15 times the travel life of similarly sized ball screws. The diagram on left shows number of contact points in ball screw as compared to the number of contact points in a roller screw.

For detailed specifications visit our website [www.servocontrolsindia.com](http://www.servocontrolsindia.com) and go to products and then to electromechanical actuators, or contact our experts at [electromechanical@servocontrolsindia.com](mailto:electromechanical@servocontrolsindia.com)

# SERVOCONTROLS

## Different Type of Control Valve

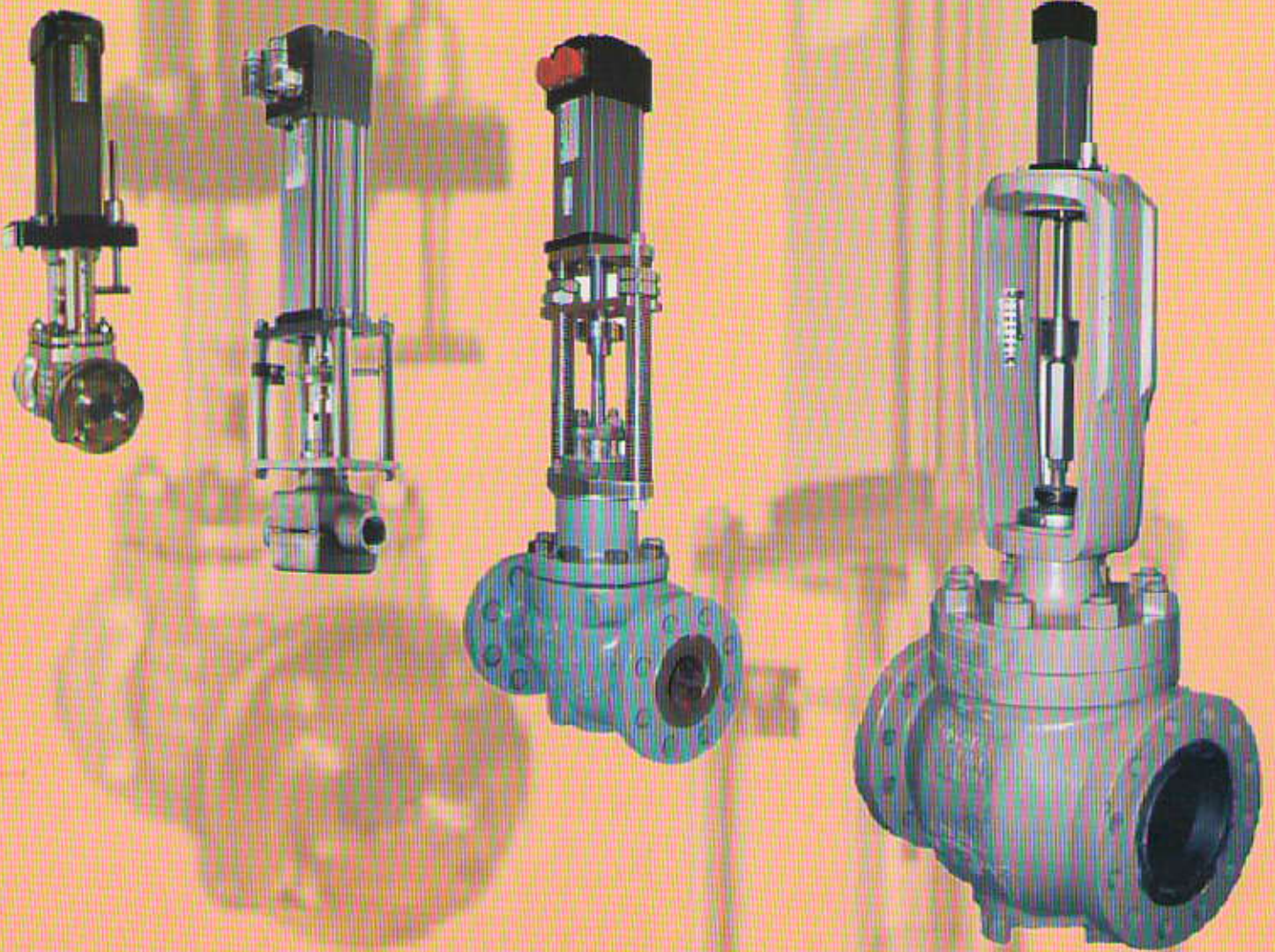

Servocontrols can retrofits and valve from any manufacturer, including: Emerson (Fisher), Samson, Kammer, Badger, Flowserve, Woodward, Masoneilan, Warren, Fox, Jordan, Leslie

# SERVOCONTROLS

## Steam Turbine Retrofit Turbine pilot valve

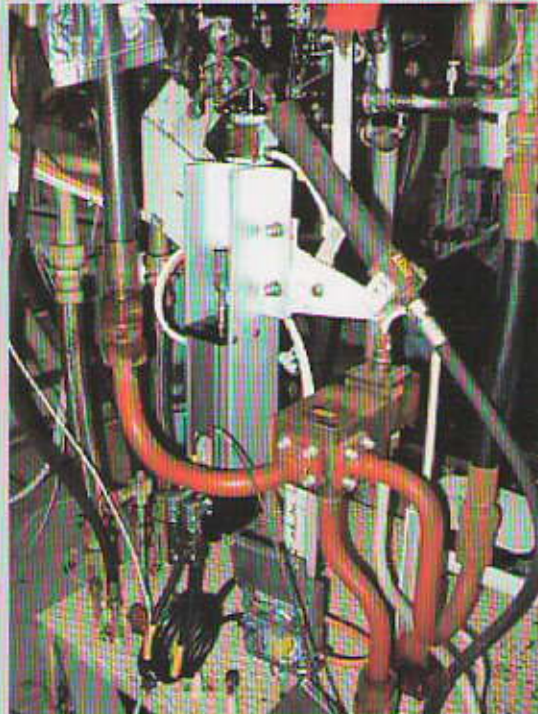

- GSX30 with SV Positioners
- High static and dynamic control accuracy
- Stiction and friction problems eliminated
- Control valve's oscillation was eliminated thereby extending steam distribution system's life, and reducing spare parts costs.

# SERVOCONTROLS

## Explosion Proof Actuators

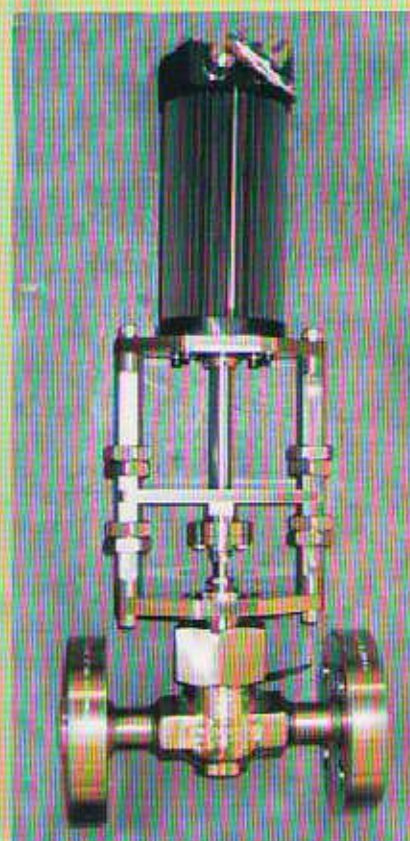
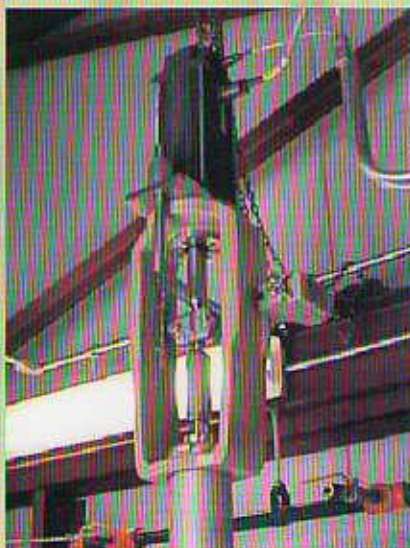

- Explosion Proof
  - Class I Div I and ATEX
  - ER Rotary and EL Linear
  - I series with ER for Linear

## Steam Turbine Retrofit

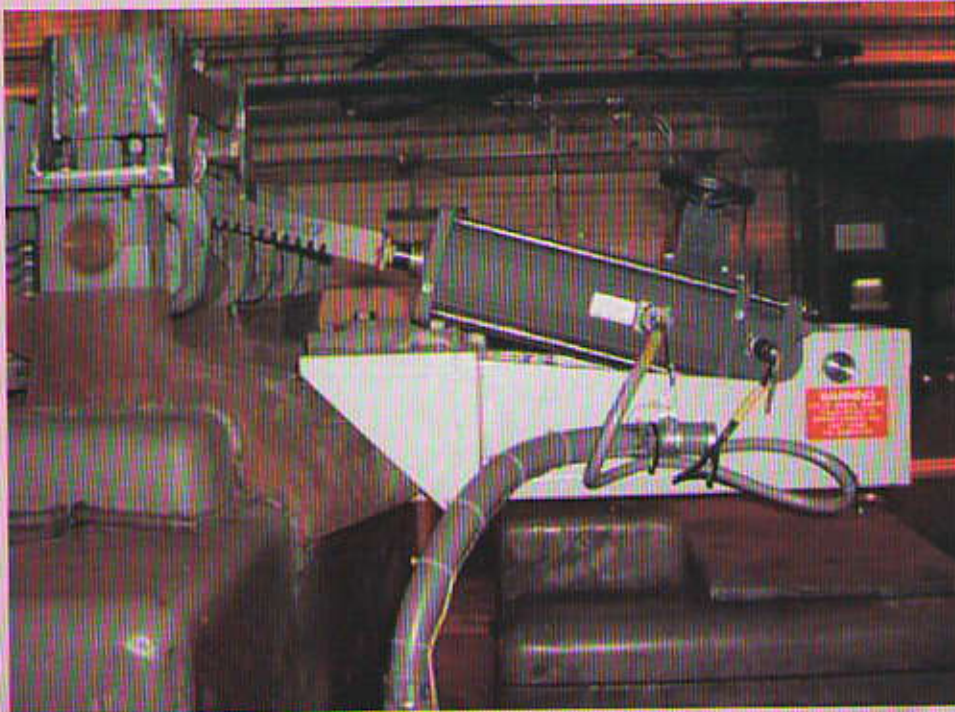

Steam Turbine Retrofit

### Eastman Chemical

- GE turbine steam control
- Direct replacement of 10 inch diameter single acting, hydraulic cylinder
- Elimination of mechanical governor operated pilot valve.
- GSX60 with a 10 inch stroke
- Handwheel for manual operation

## Other Products

### Liquid Fuel Metering Unit (LFMU)

- multifunction modular
- up to three fuel streams

### Multifunction Purge Manifold

- Dual Fuel Machines
- Modular Design

### DDV 0 Pilot, High Flow Valve

- 3,500 L/M
- Includes Dump Valve and Filter

### I/H Valve Converter (770-)

- Retrofit Applications

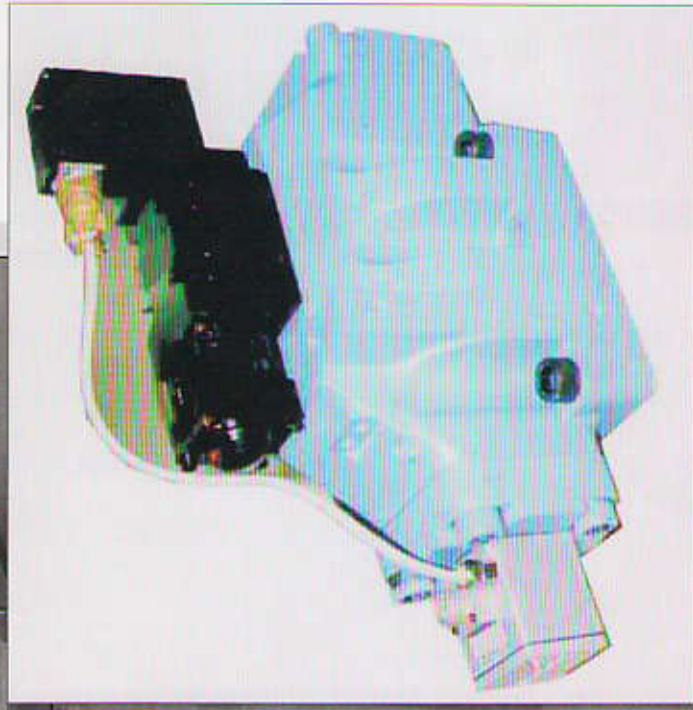
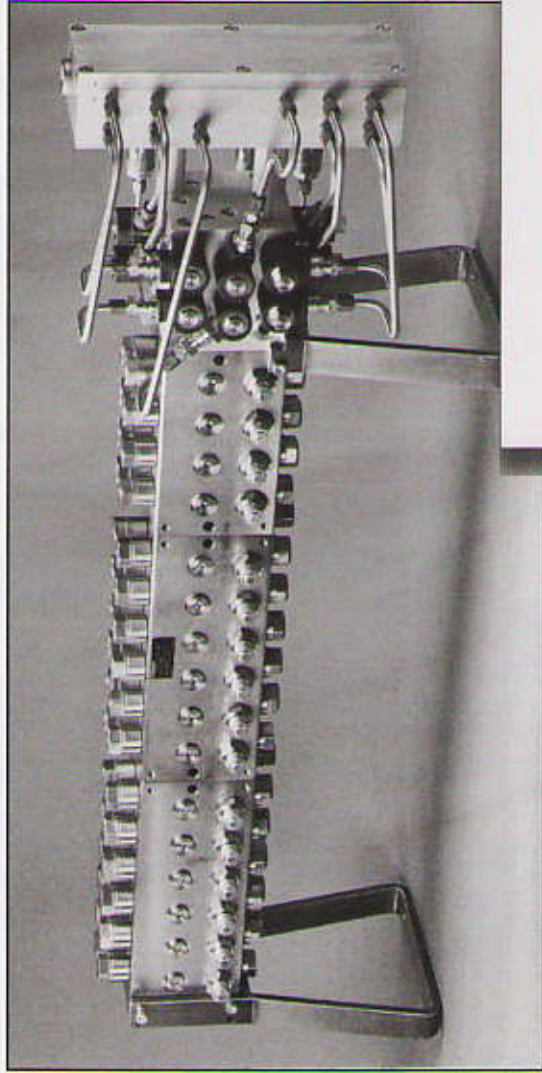

SERVOCONTROLS  
SERVOCONTROLS

# Integrated Control Valves

## • Steam Applications

- Admission/Induction
- Stop & BOP
- 15,000 to 120,000 in-lb.  
(1,700 to 13,560 Nm)

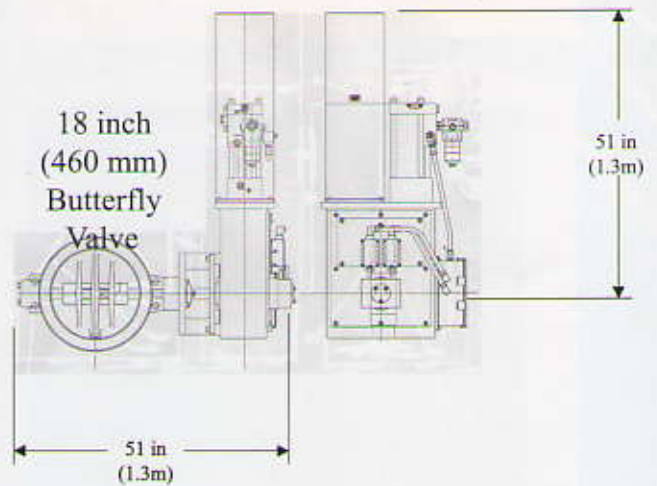

## • Disk Spring Configuration



Disk Spring

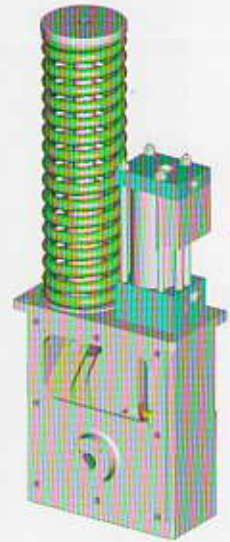
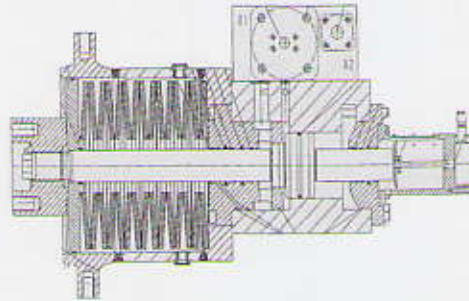

## Model Code 890

4 Port configuration - 50,8mm PCD  
2 Stage Mechanical Feedback  
High Flow Electrohydraulic Servovalve

Model Code	Nominal flow at 70 bar[lpm]
890-101	95
890-102	150
890-103	230





21st Century SERVO VALVE With SAPPHIRE Technology

### Servo Valve - Technology

The Servocontrols - Star valve utilizes a Jeweled feedback ball on their feedback wire assembly so that valve will have longer span of operation before "Giltch" effect. Our feedback wire ball is made of SAPPHIRE this is much tougher than tungsten carbide so there is no wear and tear on the ball and thus prevents null shift and null drifting, Even the end orifices are made of SAPPHIRE so there is no wear and tear inside the orifice and even contamination ie Micron level is cut into still smaller level and thus can increase the life of the valve.

To our customer where servo - valve life, performance and reliability go, our objective is to offer highest quality products and services beyond that our competitors have tried to match.

Servo Valve Technology for the 21st Century.

Servocontrol - Star innovation

"Jewel in the Crown"

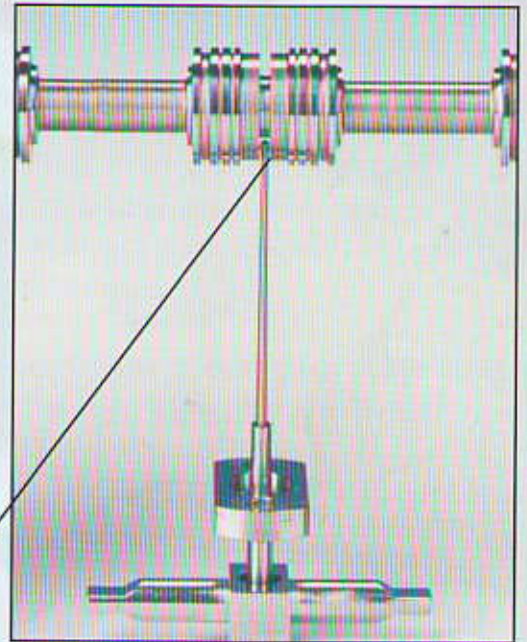

**SAPPHIRE**



Sapphire at the end of feedback wire

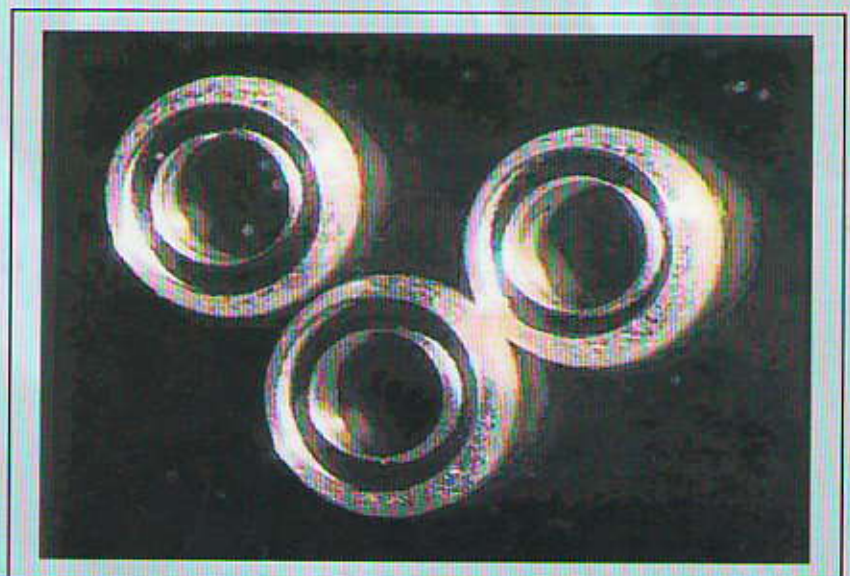

End Orifices

# SERVOCONTROLS

SAPPHIRE TECHNOLOGY



21st Century SERVO VALVE With SAPPHIRE Technology

## SERVOCONTROLS-STAR

### Model 550

4 port configuration - 22,22mm PCD  
2 Stage Mechanical Feedback  
Medium/High Response  
Electrohydraulic Servo valve

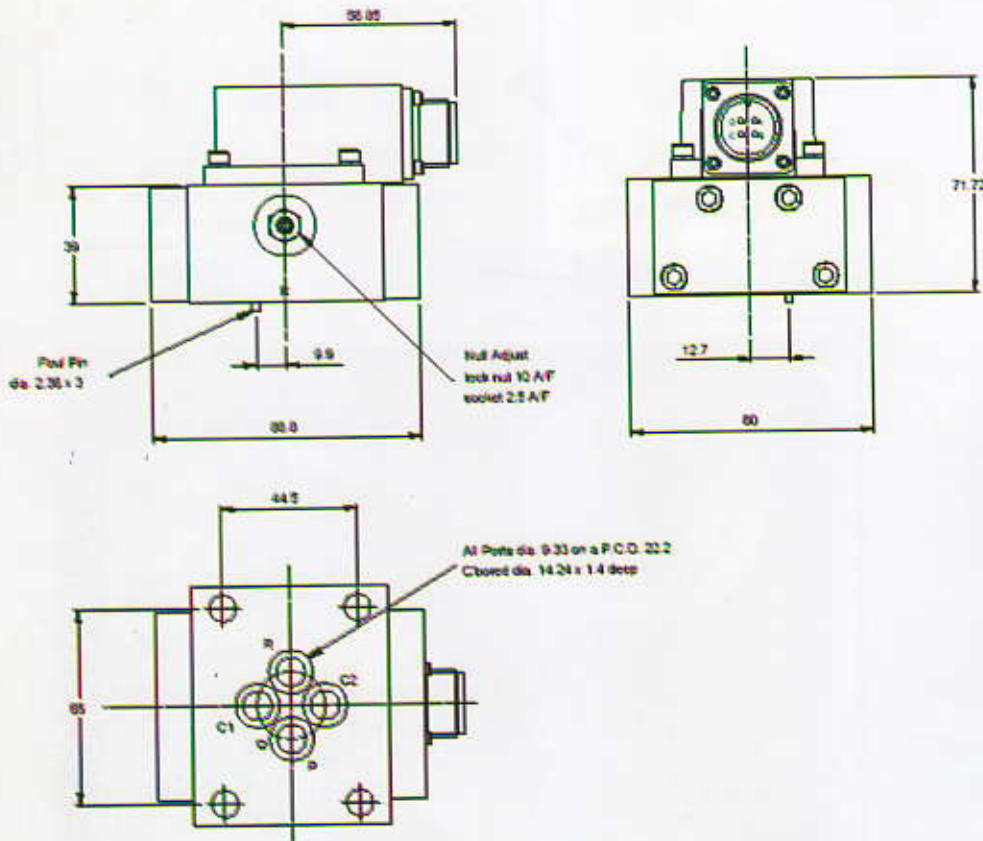

#### Ordering Code :

Model Code	Nominal flow at 70 bar [lpm]
550-101	4
550-102	10
550-103	20
550-104	40
550-105	60
550-106	75



21st Century SERVO VALVE With SAPPHIRE Technology

## Flow Vs Pressure drop characteristics :

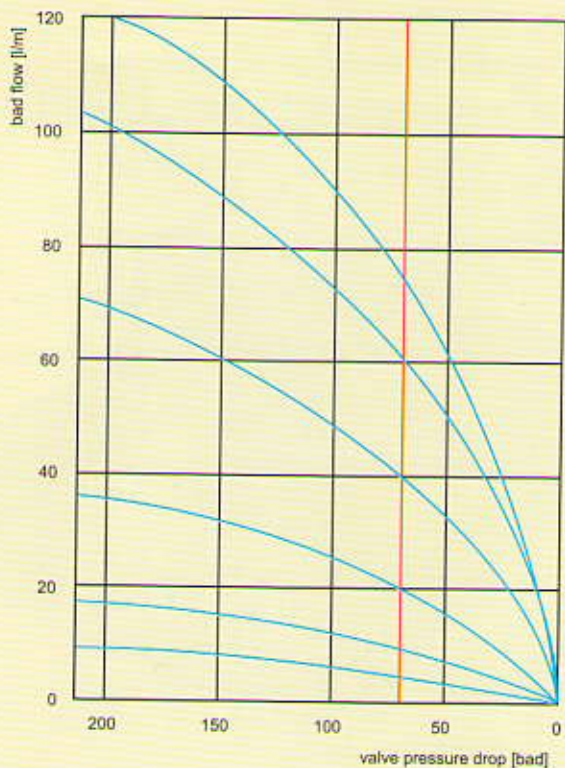

Figure - 1

The nominal rated flow of a servovalves is the load flow under conditions of 100% electrical input and 70 bar total valve pressure drop. The load flow pressure characteristic closely approximates the theoretical squareroot relationship of a sharp edged orifice (figure 1).

The flow tolerance for standard servovalves is  $\pm 10\%$  of the nominal rated flow at  $\pm 100\%$  input signal. Flow gain null is determined by the relationship of the spool and bushing metering edges and may vary with standard production tolerances, flow gain in the region of  $\pm 5\%$  rated current from null may range 50% to 200% of the nominal flow gain.

The null leakage comprises of both pilot stage flow (tare leakage) and the second stage null leakage.

## Flow Vs Input Current characteristics :

## Frequency - Dynamic Response

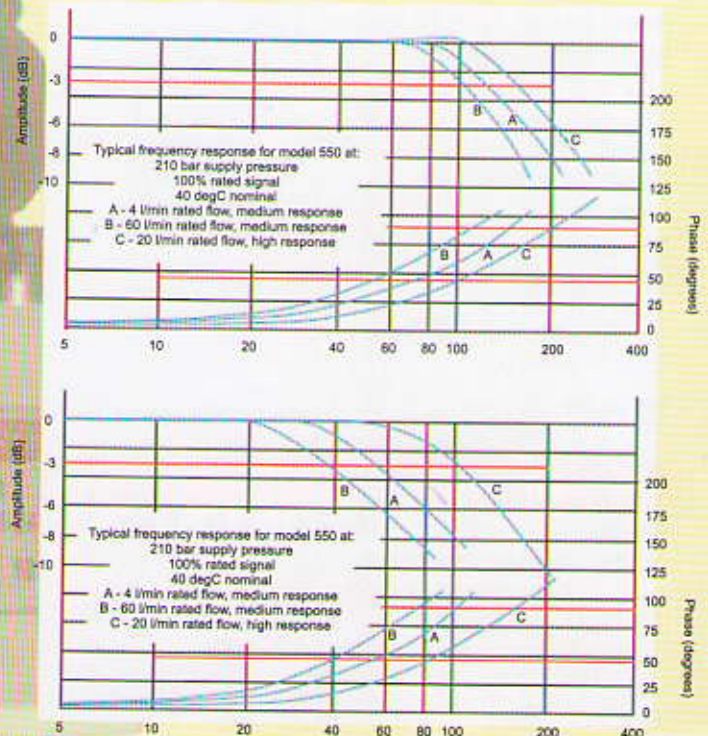
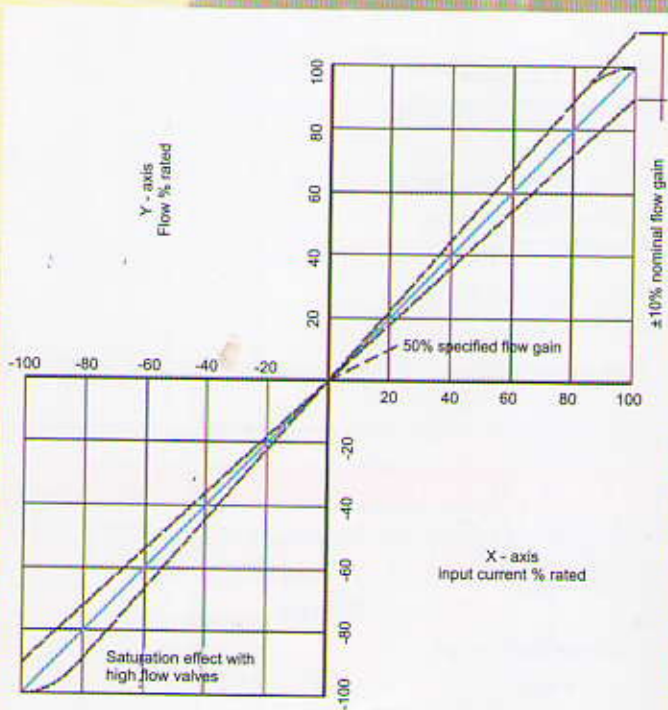

# SERVOCONTROLS



Explosion Proof, Intrinsically Safe, Nozzle-Flapper Servo valves

## Model SC771K

Model SC771K Servovalves are devices which control flow to load proportionally to control current at constant valve pressure drop. These are servovalves of explosion proof version for use in control systems of gas transportation stations.

### Design Features

- \* Interchangeable BSA with O-rings
- \* Floation of bushing by one-side pressurizing makes servovalve more reliable
- \* "Dry" torque motor
- \* 16 mm nominal filter for pilot flow
- \* Mechanical feedback with simple cantilever spring
- \* Installation pin on mounting surface ensures correct installation of servovalve
- \* Magnetic null adjustment
- \* Three - coil torque motor optional

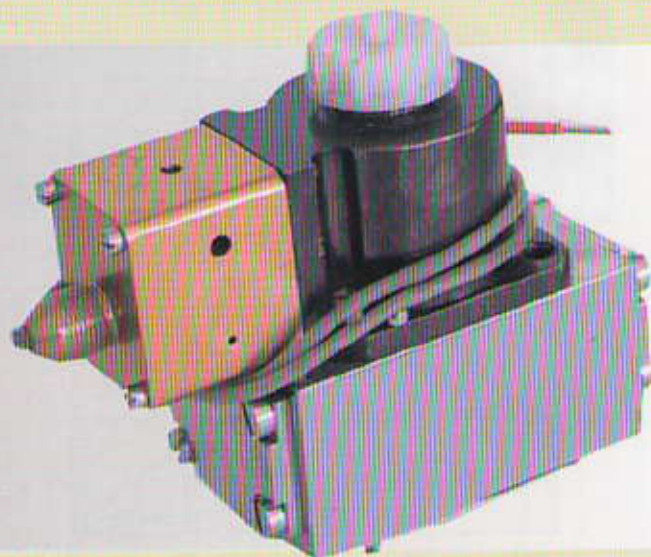

### Static Performance

Operating pressure range, kgf/cm <sup>2</sup>	70 up to 210
Rated flow at $\Delta p = 70$ kgf/cm <sup>2</sup> , l/min	20 /40
Rated current mA	5, series connection 10, parallel connection
Coil resistance, Ohms, $\pm 10\%$	1000
Hysteresis	< 3% of rated current
Dead band	< 3% of rated current
Null Bias	< 3% of rated current
Non-linearity	< 5% of rated current
Internal leakage, l/min	< 1,2
External leakage	None
Mass, kg	1,1

### Ordering information

Model	Flow in lpm @ 70 bar
SC771-103	20 lpm
SC771-104	40 lpm

### Environments

Operating fluid	Mineral oil to GOST. 174779. 3-85
cleanness class	13 class to GOST 17216-71 Or better
Temperature range	
Fluid	-30° C .... + 80° C
Ambient minus	-40° C .... +100° C

# SERVOCONTROLS

Explosion Proof, Intrinsically Safe, Nozzle-Flapper Servo valves



## Dynamic Performance

Frequency response  
for SC771K (40 L / min)

Valve Pressure drop  $\Delta p=210 \text{ kgf/cm}^2$   
25% of rated current

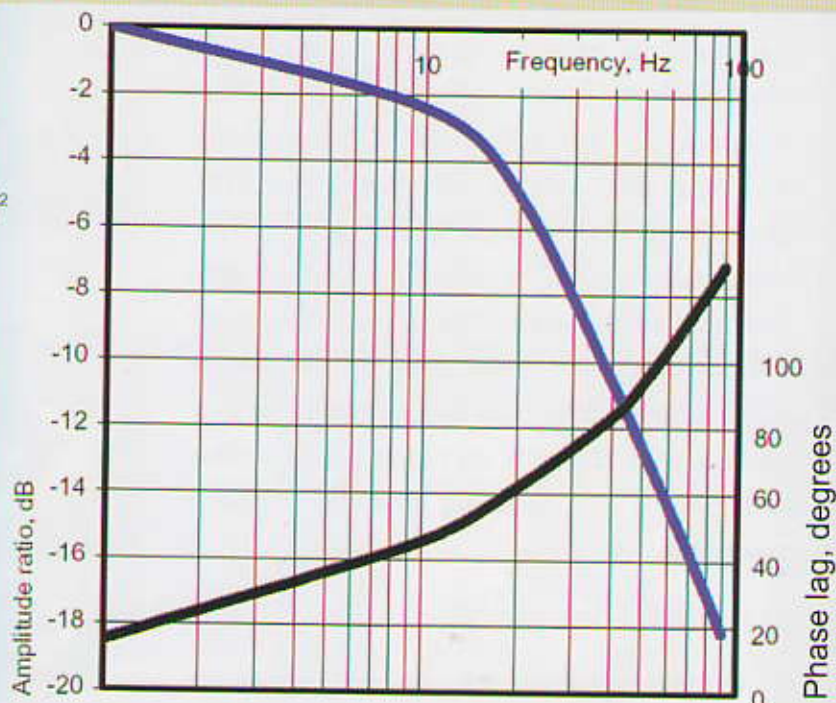

## Installation Details

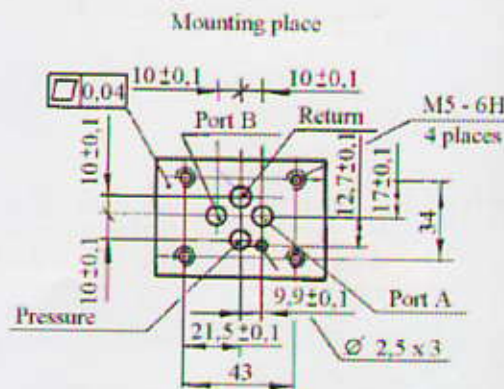
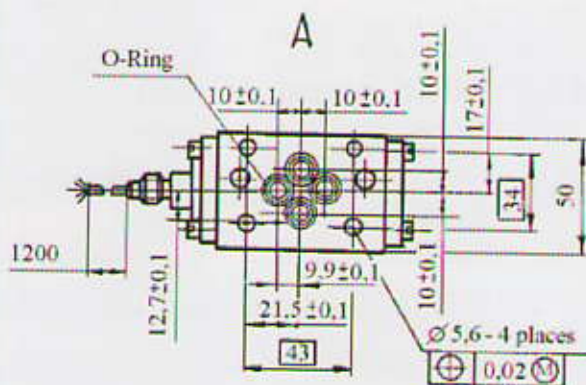
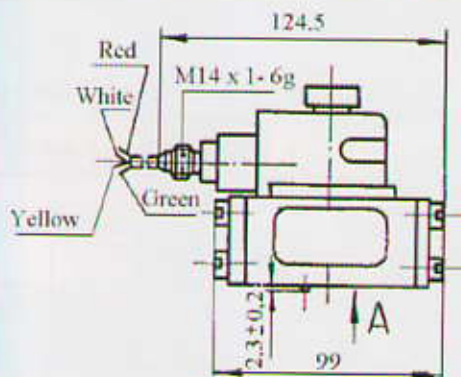

## DIRECT DRIVE VALVE (DDV) - SC 633 / SC 634

A Direct Drive flow control proportional valve with a high force level permanent magnet linear force motor directly driving the spool. A LVDT is attached to the spool to provide spool position feedback. An internal loop is closed around the spool position. This is one of the best DDV available in the world performance wise. You can directly replace the existing servovalve with this high performance DDV and get the same performance with added high resistance to contamination of oil. The unique feature of this valve is that "There is no null leakage" unlike other DDV's thus reducing power loss at null operation.



### SC633 - XXX (Standard Valves)

± 10 Volts Input, lpm at 35 bar each land.

Model	Flow in LPM
SC633 - 101	5
SC633 - 102	10
SC633 - 103	20
SC633 - 104	40

± 10 mA Input, lpm at 35 bar each land.

Model	Flow in LPM
SC633 - 201	5
SC633 - 202	10
SC633 - 203	20
SC633 - 204	40

### SC634 - XXX (Standard Valves)

± 10 Volts Input, lpm at 35 bar each land.

Model	Flow in LPM
SC634 - 101	60
SC634 - 102	100

± 10 mA Input, lpm at 35 bar each land.

Model	Flow in LPM
SC634 - 201	60
SC634 - 202	100

# SERVOCONTROLS SERVOLAB - Repair & Servicing



We have set up the state of art Servo system Lab and Toolroom at our works in Belgaum, Karnataka which is one of its kind in entire India. In this facility we have set up the assembly, service & repair center (level I, II and III) for all closed loop components like servovalves, Servoactuators position / velocity / pressure / force loop, electric controllers.

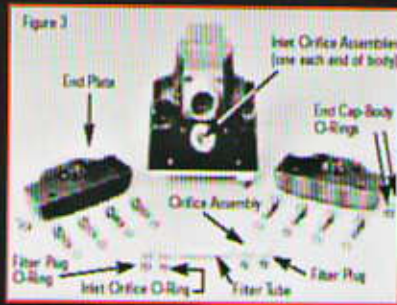

Moog 760 series

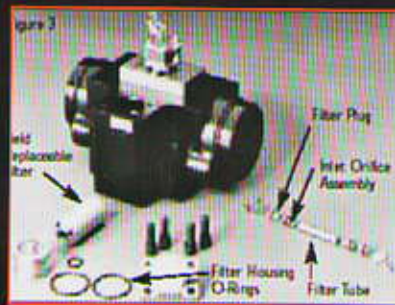

Moog 72 series

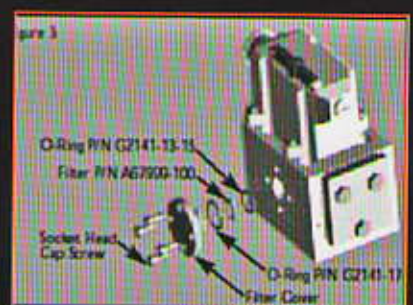

Moog 631 series



Oil Gear Servo Valve



Moog 79 series



TSS - Servo Valve



Moog 79 series

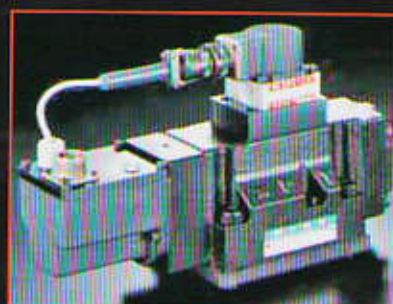

TSS Servo Valve

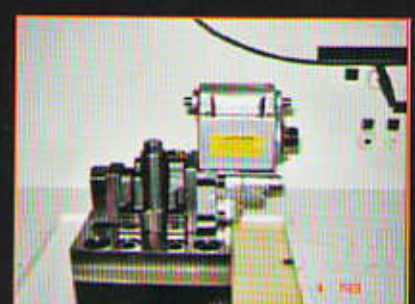

North American - Servo Valve



Sopenem / LHC series



Torque motors and filters



Rexroth - Servo Valve

# SERVOCONTROLS

## PORTABLE TEST RIG

### SERVOCONTROLS Portable Test Rig

Model SC-087-117A-00



**Servocontrols offers a most economical portable test rig for testing Flow, Null leakage & the performance of servo / propotional valves.**



## SERVOCONTROLS Portable Test Rig

### Features :

1. Can test Null Leakage & Flow test of Servo valve.
2. Can set Null Offset of Servo valve with / without an electrical signal.
3. Servo valve functionality with command signal.
4. Movable test rig

### Main function :

1. This test rig helps to make sure either new/ serviced or old servo valve is Okay or malfunctioning.

### Portable test rig includes the following

1. 40 Lpm Flow meter with digital display
2. Pressure gauges 0 - 350 bar,
3. 760 series manifold plate,
4. Control Valves (Loading valves)
5. Command signal 0 to +/- 100mA with digital display.
6. Polarity switch
7. Inbuilt Pressure line filter & Return line filter.
8. Cable with standard 4-pin connector.
9. 3/8 Inch BSP Quick Disc connect coupling (Female).
10. 240 V AC Power Input

# SERVOCONTROLS - SENSTRONICS PRESSURE TRANSDUCERS

(Which are most compact using the state of the art ASIC technology)

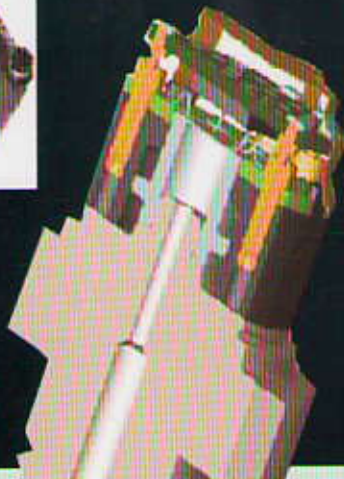
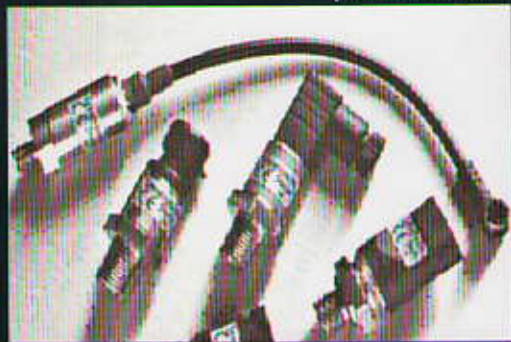

Pressure transducers used in Turbine industry for pressure control are built on Thin Film Technology. The Servocontrols - Senstronics thin film technology and its manufacturing process have no equals a just reward for six years dedication and research for uncompromised perfection. Manufacturing process is called TCAS which means "Thermal Compensation at Source". TCAS with thin film technology ensures a staggering thermal accuracy of 0.005% / degree C and compensate for any ambient change in temperature & also to withstand the pressure spikes which are typical in Turbine Industry with special snubbers.

## Ordering code for Pressure Transducers

SCP	X	G	XX	X	X	3	U	A	
Pressure Transducer		Performance Code		Approval and Protection		Electrical Connection		Pressure Connection	
Output Voltages		A - 0.25% / 2%		3 - CE		1 DIN 43650 ( IP65)		1 G 1/4 "	
1	0.5 - 4.5 Volts	U - No cable				3 Bayonet DIN 72585 (IP69K)		2 1/4" NPTF	
3	0 - 5 Volts					4 AMP (Superseal) (IP67)		3 1/8" NPTF	
4	0 - 10 Volts					5 M12 X 1.75 4 Pin (IP67) with Pigtail and 3 feet long cable		4 M12 X 1.5 = 600 Bar with Spigot	
5	4 - 20 mA					6 Deutsch DTD 4 - 4P		5 7/16" - 20 UNF	
6	1 - 6 Volts							6 G 1/4" External S/S	
7	1 - 5 Volts							7 G 1/4" External Manometer	
8	0.5 - 4.5 Ratiometric							8 M12 X 1.5 = 1000 Bar	
9	MV 10 - 25 MV								
Pressure datum									
G - Gauge									
Pressure range in bar									
1	6								
2	10								
3	16								
4	25								
5	40								
6	60								
7	100								
8	160								
9	250								
10	350								
11	400								
12	600								
13	1000								
14	1500								
15	2200								

**Note 1:** Pressure output available with voltage output and electrical connectors 1,3,5 and 8 only.

**Note 2:** mV unit available with Electrical connector "E" only.

**Note 3:** Ranges 1000 bar and above available with "8" pressure port only.

# SERVOCONTROLS

## SERVOCONTROLS - DELTA Closed Loop Controllers

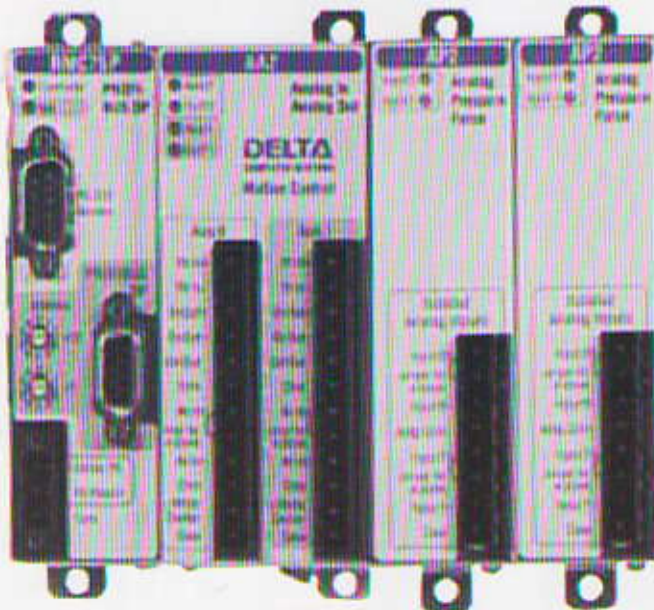

**RMC - 70 CONTROLLER**

*Servocontrols* - Delta Computer offers Motion Controllers for servo-hydraulic and servo - motor applications featuring fieldbus communications, Ethernet, PROFIBUS - DP, Modbus Plus, Serial and Digital I/O (25 + Protocol). Connect I/O with Mix and Match transducer modules allowing more than 500 configurations. Use powerful RMC win software (earlier used with Cegelac Controllers ) to easily setup, tune and diagnose your applications.

### OPEN COMMUNICATIONS :

Any PLC, Any Computer, Any System Control motion and transfer real-time SPC motion data over a distributed fieldbus or use just a few push buttons in a stand alone application.

PROFIBUS - DP  
ETHERNET  
MODBUS I/O  
DISCERTE I/O  
RS - 232/422/485 SERIAL

High Performance Motion Control, Flexible, Optimised.

Long years of experience in Servo hydraulic and motor control bring your algorithm that do more than simply work well they squeeze performance out of your system.

PID with extend and retract feed forwards for both velocity and acceleration synchronizing, gearing, superimposed mover Trapezoidal, S-Curve and spline profiling. Profiles changeable on the fly teach modes.

## SERVOCONTROLS - DELTA Closed Loop Controllers

MDT (Magnetostrictive Displacement Transducer) Interface. Connects directly to all major magnetostrictive linear displacement transducer brands like MTS - Temposonics and different types, including multi magnet.

### 12 and 16 bit analog :

Bring in position, Velocity, pressure or analog reference use the 16 bit version for motion control with analog feedback, or for high resolution force control.

### Quadrature Interface :

hook up with encoders and glass scales Control servo motors or stepper or bring in for gearing.

### SSI Interface :

Use with MDTs, resolvers, and absolute encoders equipped with a synchronous serial interface.

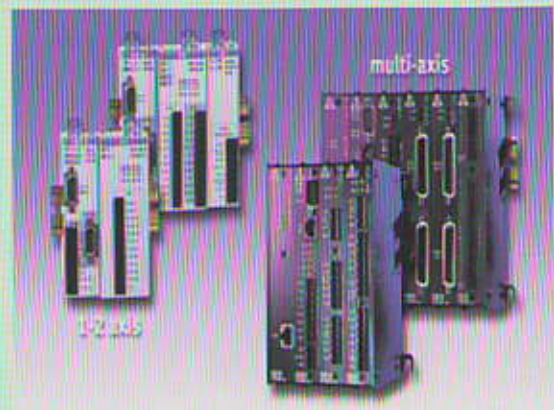

Connect, Control, Optimize

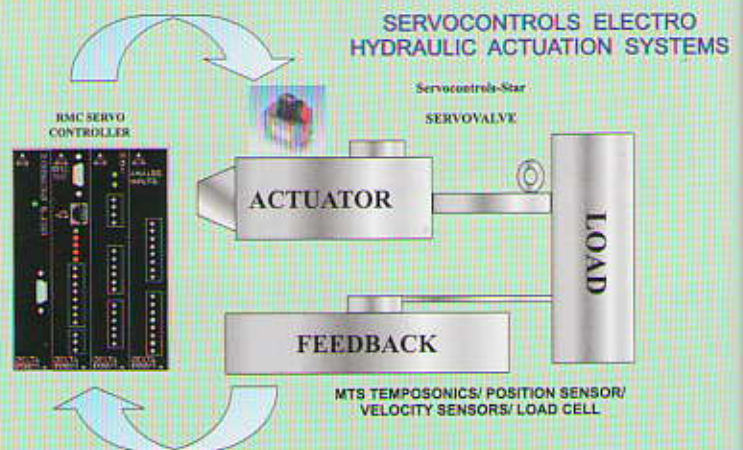

## RMC Companion Products



**Voltage to Current Converter :** High Performance & High Bandwidth V to I converters are designed for converting a voltage drive o/p to a current drive output in order to control a serv valve application.

### Features :

- ◆ Two channels of Voltage to Current conversion.
- ◆ Full scale output current switch selectable from (0 to  $\pm 10$  Volts)  $\pm 10$  mA to  $\pm 100$  mA.
- ◆ Input and outputs can be paralld for output current.
- ◆ LED to indicate input polarity and amplitude.
- ◆ LED to indicate output saturation.
- ◆ Compact DIN - rail mount package.

## CLOSED LOOP POSITION AND PRESSURE TESTING/DIAGNOSTICS

Online diagnostics and data acquisition using our closed loop controllers will help you to tune your gains. Our controllers are inbuilt with special algorithm to take care of null shift of servo valves. Irrespective of change in null position of servo valves the controller adjust itself to overcome the null changes in servo valves thus reducing valuable downtime in Turbine Industry.

This is the unique algorithm developed by Servocontrols for Turbine Industry, and any closed loop applications.

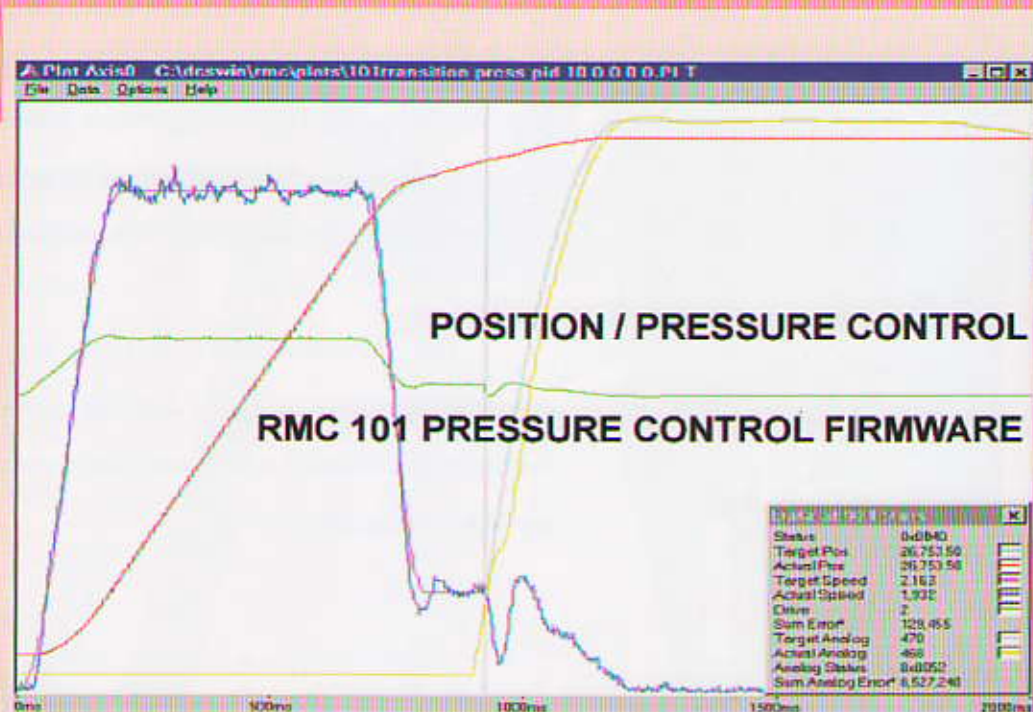

## Servocontrols - Ormec SMLC Controller



Servocontrols - Ormec's Servowire Motion and Logic Controller is at the center of complete machine control solution that can meet all of your motion, I/O and networking needs. With Pentium processor, Firewire Drive networking and Ethernet connectivity, SMLC allows to focus on solving application instead of integrating control components. The SMLC Servowire drive network and Modbus/TCP provide state of art I/O and motion control up to 16 axes, programmed using IEC 61131 - 3 standard language including relay ladder logic.

The Servowire Motion & Logic Controller features high performance computing capability combined with true real time operating systems (RTOS). This system is cost effective and having robust computing power for multi-axes motion and I/O control applications.

## Servocontrols - Ormec Drives

Servowire SM drives provide high performance servo operation utilizing digital networking technology based on IEEE - 1394 (Fire Wire). Each servo drive supports a variety of high performance, encoder based servomotors. All servowire drives utilize IGBT based intelligent power modules and provide cost effective solution for motor control applications. Servowire SM drives combine all digital operation with DSP technology to produce fast updates and correspondingly high performance. The high bandwidth control loops in Servowires along with high resolution motor feedback combine quick and accurate torque, velocity and position control. Position, velocity and torque loops are all closed in Servowire SM drives.



3 PH, 230 Volts Inputs. 3 PH, 460 Volts Input +/- 10 Volts Input & 230 Volts Input

# Servocontrols - Ormec Motors

Servocontrols - Ormec brushless motors provide high torque to inertia ratios and excellent continuous torque and peak torque performance in a compact design. These industrial quality servomotors incorporate high energy, rare earth, neodymium - iron - boron magnets and a highly efficient stator winding design which results in excellent power density. These servomotors also completely eliminate brushwear, Maintenance problems, extremely durable construction, rugged MS connectors provide reliable interconnections to both motor and optical encoder.



## Features :

- ◆ Continuous stall torques from 0.3 to 75 Nm.
- ◆ High peak torques from 0.96 to 113 Nm.
- ◆ Output power from 0.13 to 15 HP.
- ◆ High maximum speeds up to 5000 rpm.
- ◆ Class B or F insulation providing long winding life under rated operating conditions.
- ◆ Minimum torque ripple and cogging for smooth low speed performance.
- ◆ Totally Enclosed Non Ventilated (TENV) standard (IP 67).
- ◆ Optional fail safe holding brake.

## Accessories :

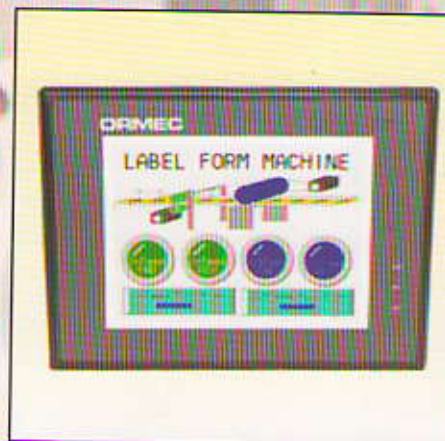
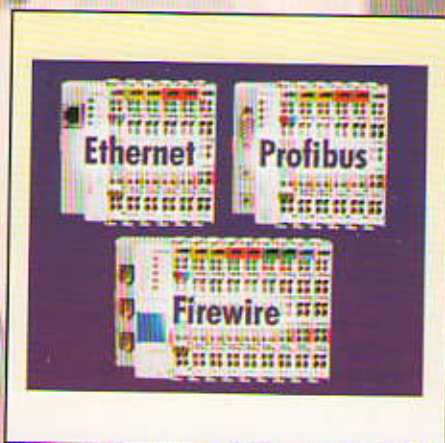

HMI Screens

# SERVO LAB

## INDIA'S BEST SERVOVALVE REPAIR LAB.

We have a huge inventory of Servovalves, Tube Filters, Cartridge filters, Disc filters, Last chance filters, Torque motors, Seal kits, O-ring sets, Connectors, Coils, Electronic cards. We repair/service Proportional, Servo-Proportional and Servo valves.

## ALL BRANDS, ALL TYPES, ALL CONFIGURATIONS.

Abex, Atchely, Cincinnati, Dowty, Dyval, EMG, Heroin, Hydromatic, Kawasaki, LHC, Moog, Oilgear, Olsen, Parker, Pegauses, Plasser, Rexroth - Bosch, Schneider, Sopelem, Towler, TSS, Ultra, Vickers.



### LEVEL I SERVICING:

Functional Test and Preparation of a cost Estimate filter inspection, change of filter if necessary. Cleaning and final functional test with Null Leakage & Expanded flow plot tests.

### LEVEL II SERVICING:

Level I + Functional Test with installation of new feedback assembly (Armature Flapper Sub Assembly, (AFSA)), repair of first stage. Electronic card testing + assembly. Final test with null leakage and expanded flow plot tests.

### LEVEL III SERVICING:

Level I + Functional test with installation of Bushing & Spool Assembly (BSA)/Torque Motor, Third stage electronic repair/lvdt repairs and final test with Null Leakage & Expanded flow plot tests.

We will be providing the Initial Inspection Report, Final Test Report along with Null leakage and expanded flow plots. We will set the customized null condition and fail safe condition depending on the customer application/input.

**Deepak Dhadoti**

Mobile : 9448395734

**Dinesh Dhadoti**

Mobile : 9845109022

Survey No. 683, Industrial Estate,  
Udyambag, Belgaum - 590 008.  
Karnataka, India.

Tel. : 91 - 831 - 2407501/2/3/, 2481734, 4201132, 4202251

Fax : 91 - 831 - 2484496

E-mail : [powergen@servocontrolsindia.com](mailto:powergen@servocontrolsindia.com)

Website : [www.servocontrolsindia.com](http://www.servocontrolsindia.com)