



Electrohydraulic Control Solutions For

Excavators



www.hydraforce.com

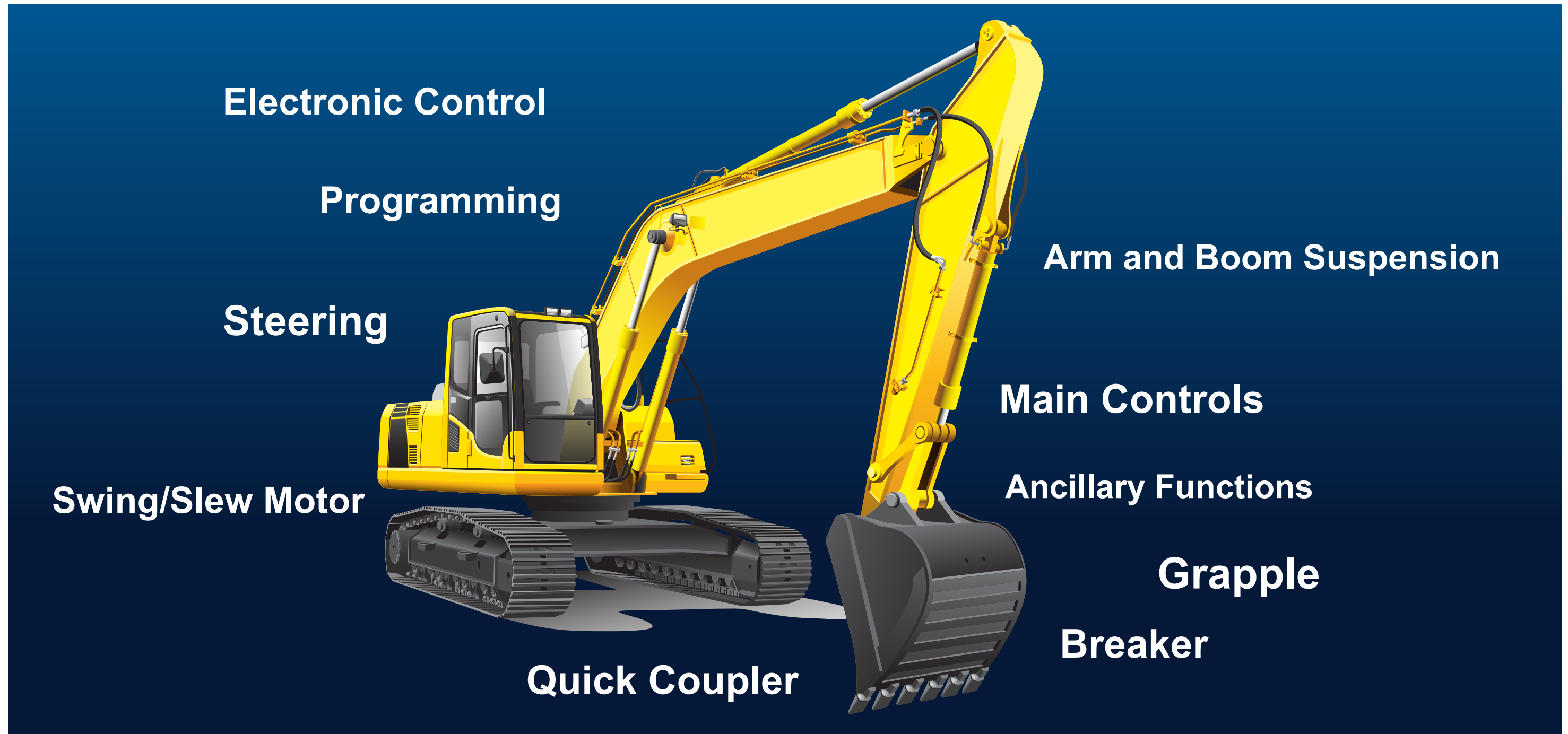

TECHNOLOGY AND EXCAVATORS

Mini and mid-range excavators up to 20 tons can gain the greatest benefit from inventive application of electrohydraulic controls. Virtually all movements of the cab, boom, arm, and bucket are hydraulically controlled and easy to integrate into

hydraulic manifolds. HydraForce, with its comprehensive line of cartridge valves and manifold capabilities, can provide numerous custom control solutions for excavators.

CONTENTS

POWERTRAIN - PAGES 4-5

Transmission, Drive Motors, Fan Drive, Clutch

SUSPENSION SYSTEMS - PAGES 6-7

Bucket, Arm, and Boom control

MAIN CONTROLS - PAGES 8-9

Boom, Bucket, Swing/Slew Motor, Return Manifold, Steering

AUXILIARY FUNCTIONS-PAGES 10-11

Breaker, Grapple, Hammer, Auger, Quick Coupler

THE HYDRAFORCE DIFFERENCE- PAGE 12

Highest quality guaranteed, flexible and responsive

ELECTRONIC CONTROLS-PAGE 13

Rugged and reliable, Hardware and Software

POWERTRAIN AND TRANSMISSION SOLUTIONS

Excavator powertrain solutions encompass improvements on the transmission, drive motors, fan drives and clutch. Reducing emissions, noise, and vibration and improving speed, power and cooling are the goals. Operator comfort and productivity can be enhanced with improved fan and transmission control. Here are some ideas.

POWERTRAIN OPEN LOOP CAVITATION PROTECTION

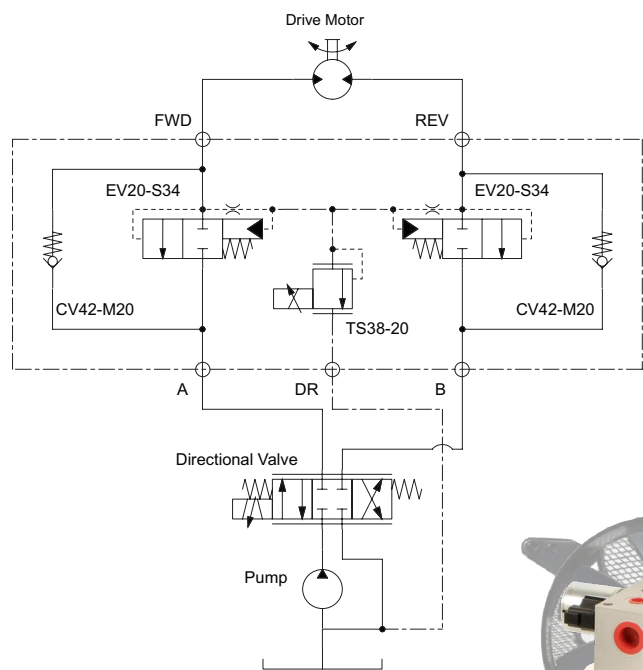

EXCAVATOR TRANSMISSION SOLUTION

Four TS98-T34 valves are used to shift clutch packs. The TS98-T34 valve is a cost-effective, pilot-operated, spool-type proportional pressure reducing/relieving valve with a built-in solenoid coil.

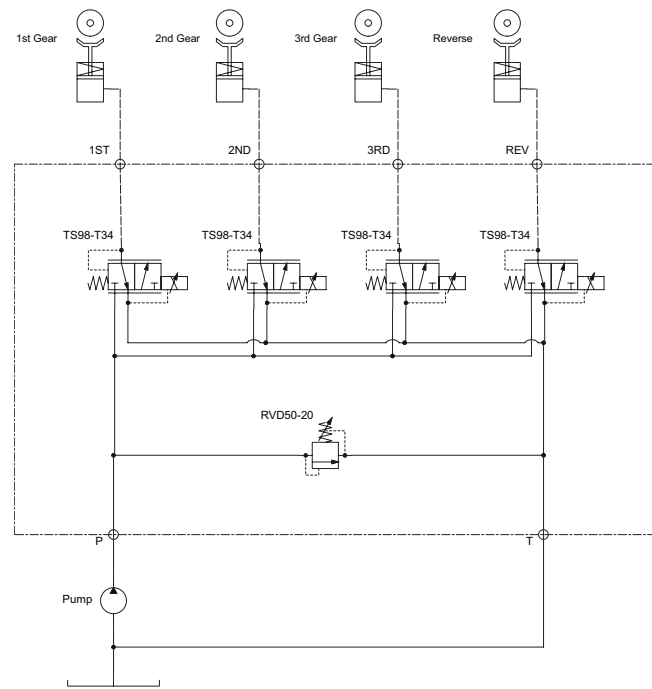

FAN DRIVE SOLUTIONS

- Flow rates up to 190 lpm (50 gpm)
- Fail safe high or low
- Preconfigured controls available
- Reduce horsepower consumption by up to 30%

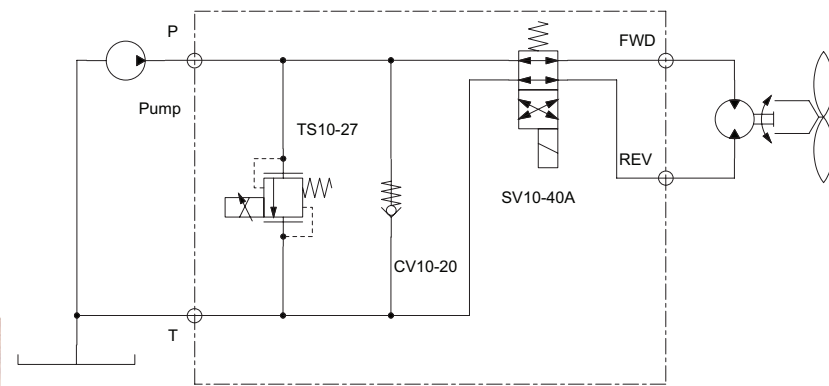
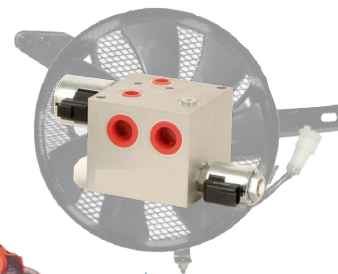

A LOGICAL AND ENERGY-SAVING SOLUTION FOR ANTI-CAVITATION ON THE DRIVE

Excavator powertrain open loop systems are vulnerable to cavitation and, due to the great demand for hydraulic power and smooth operation, an anti-cavitation check valve is commonly employed. This, however, has drawbacks, these being energy consumption in heat generation, pressure rise of counterload at higher drive speeds and higher fuel consumption.

HydraForce has another anti-cavitation solution – modulating the counter load with a simple circuit consisting of a proportional pressure control valve with two logic elements. This circuit adjusts the counter load to provide a constant load regardless of drive speed, reducing it to a very low load when not required. The result – less input energy and fuel consumption, CO2 output and oil cooling demand.

CLUTCH ENGAGEMENT PERFORMANCE (TS98-T34)

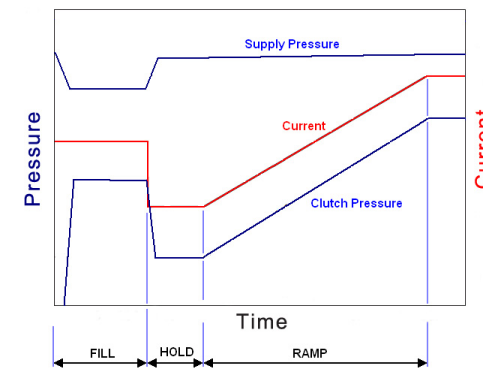

“An electronic control unit can **synchronize** proportional valves... to **regulate** forward, reverse, and multiple clutch actuation with **smooth and accurate** control of pressure.”

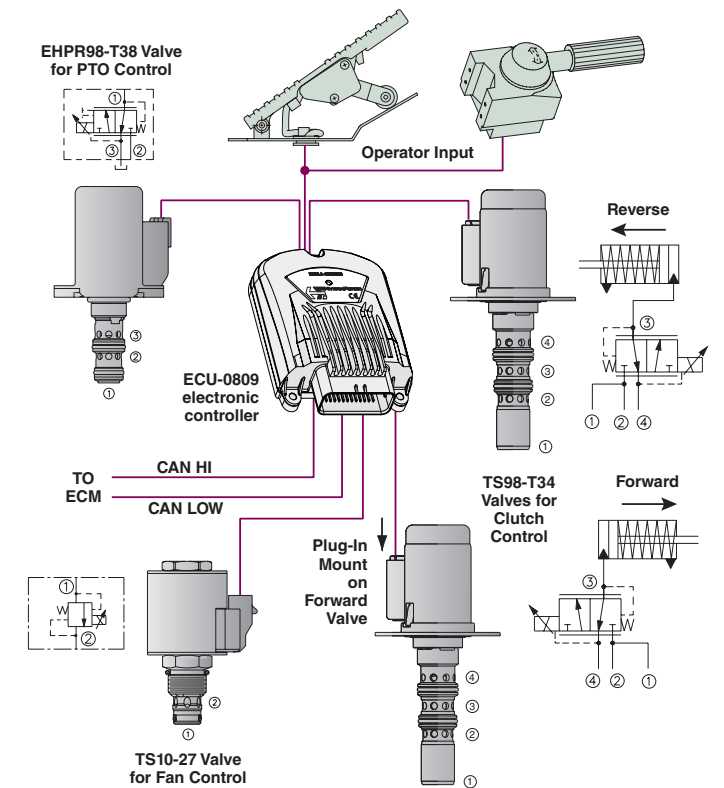

QUIET DOWN THAT FAN...

Fan drives controlled by hydraulic cartridge valves are quieter and run on less horsepower than mechanical fan drives, providing greater fuel economy for excavators.

Control valves with multiple temperature inputs can be used to provide variable fan speed control depending on air temperature, load, and cooling requirements. If the radiator gets clogged, two-position, four-way solenoid valves can automatically reverse fan direction.

Electronic control of the hydraulic cooling system can be achieved using either an EFDR1 programmable valve driver or a CoreTek controller (ECU).

FAN OUTPUT PERFORMANCE

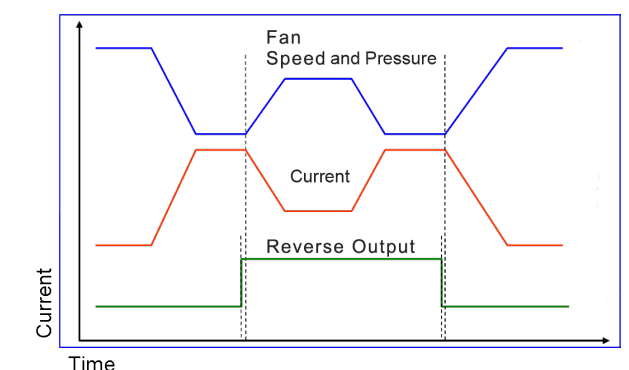

SUSPENSION SYSTEMS

Faster, smoother, and more powerful arm and boom action is made possible with hydraulic cartridge valves. Regenerative circuits can save energy and improve cycle time. Flow sharing can smooth the control of lifting and load handling. Multi-function hydraulic controls can provide flexibility and ease of operation for bucket and attachments. Systems can be tailored to the customer's exact requirements for hydraulic flow and pressure.

SYSTEMS WITHIN REACH FOR ANY EXCAVATOR

No matter what size the excavator, HydraForce can create a suitable control system for bucket, arm, boom, and suspension. Systems can be designed to suit the exact requirements of the customer, and address special needs such as pressure spikes, energy-savings, and cost-savings.

PRESSURE SPIKE SOLUTION

One way to solve the issue of pressure spikes is to incorporate an EP hydraulic directional element into your circuit. This valve can be used to reduce the overshoot spike in a closed center load-sensing system by popping open momentarily, allowing the hydraulic pump time to de-stroke when needed. As long as the spring value of the valve is slightly higher than the low-pressure standby setting of the pump, the valve will stay closed until the cylinder bottoms out. Since load-sense pressure is not maintained, the valve will open while the pump de-strokes, which effectively "clips" pressure spikes.

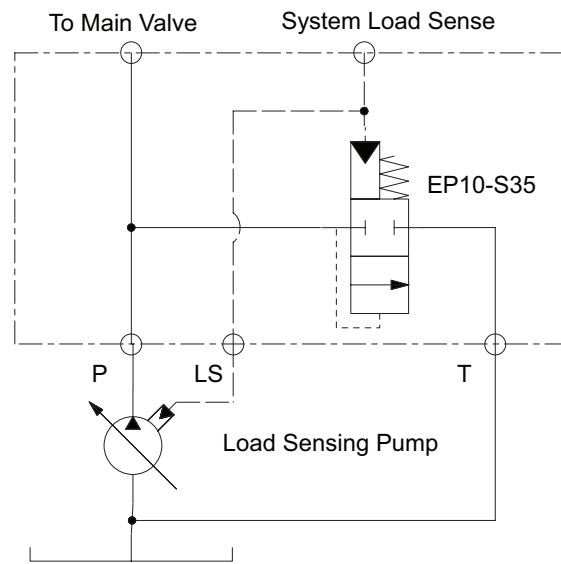

PROPORTIONAL RELIEF

For high capacity systems, a proportional relief valve system can be a great relief for the excavator operator experiencing an overload. In this system, an electrohydraulic proportional TS valve is used to provide load-sensing relief of the EV directional element.

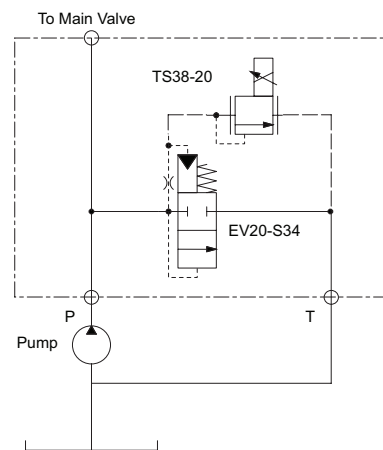

SAFE BOOM LOWERING

When excavators or backhoe loaders are doing heavy lifting, it can put a strain on the hydraulic system. An unexpected spike in pressure or flow could cause a hose to rupture, endangering the load and the operator. To protect against this possibility, a lowering control device can be used to prevent boom or arm drop and ensure controlled lowering of the load in the event of a hydraulic line failure. Equipment safety regulations now require the use of such devices.

The HydraForce EBLV boom lock valve takes a unique approach by controlling pressure rather than flow. It has a poppet seat for low leakage and spool-type metering for improved control. It is internally piloted, without the need for additional pilot lines or sources. The pressure control valve has an integrated housing that also contains a built-in check valve that provides free reverse flow.

BASIC BOOM SUSPENSION CIRCUIT

This basic suspension circuit for a wheeled excavator, working in parallel to the main directional control valve, can be incorporated to damp the effects of rugged terrain on your load. This on-off solution, when energized, uses a piloted directional element combined with a damping accumulator to smooth out the bounce on the bucket, effectively keeping more of your load in your bucket during transport. When de-energized a network of check valves and tuned orifices are used to regulate accumulator pressure.

THE UNIQUE REQUIREMENTS FOR AN EXCAVATOR BOOM SUSPENSION

Excavator boom suspension systems are quite different from the ones used in wheel and backhoe loaders. Excavator booms can be single-piece (mono boom), or two-piece. Forces on the boom suspension cylinders will vary tremendously.

Safety requirements are also different. Hose rupture valves (counterbalance valves) are absolutely necessary for the boom cylinders of an excavator.

Excavators transport loads but they also perform work from a stationary position. When excavating, there should be no drift of the boom when the suspension is switched off. The operator must be able to use the excavator for accurate work when not transporting a load.

Excavators therefore need a completely customized control solution, which often has to be flanged directly on the boom cylinder(s) and take up as little space as possible.

HydraForce cartridge valves and manifolds, especially the vibration-resistant HyPerformance™ valves, are perfect for use on excavators because they can be designed to fit a machine's tight clearance requirements and attach to a specific mounting bracket.

Figure 1: Optimally sized custom boom suspension manifold

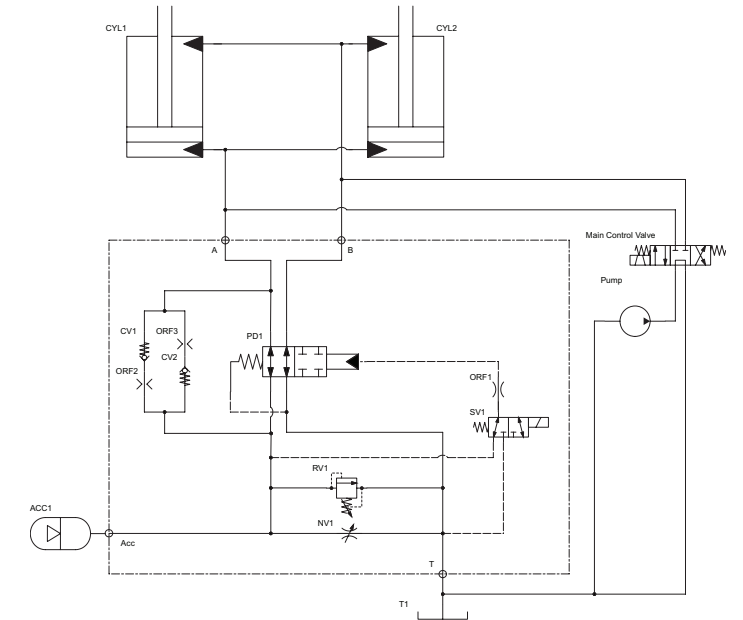
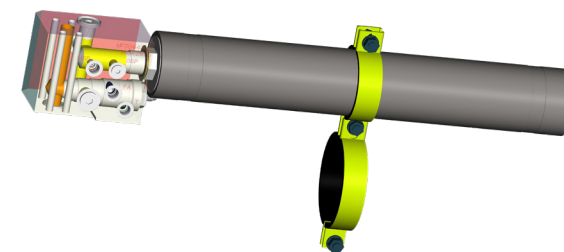

Figure 2: Without Boom Suspension

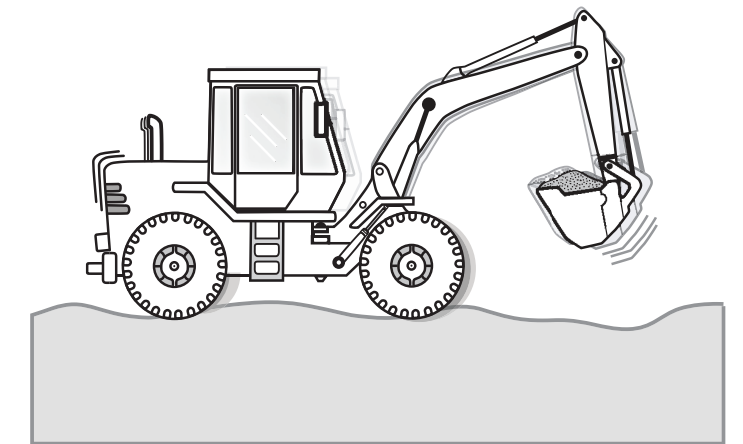
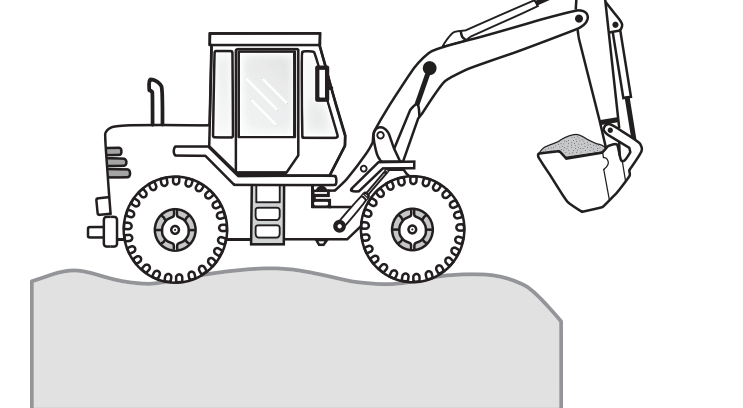

Figure 3: With Boom Suspension



Excavator main controls are filled with **opportunity** for elegant electrohydraulic control of the **bucket, boom, cab, stabilizers, swing** **OR** **slew motor, and steering.**

CONTROL OF A "WALKING" EXCAVATOR

Excavating on a mountainside or in a riverbed can be easily accomplished with the help of a "walking" excavator. Its wheels are mounted on foldable "legs" that are controlled hydraulically by the same manifold that provides steering control. When the excavator works in a riverbed, the manifold and cartridge valving can be totally submerged in water, thanks to their corrosion-resistant coating.

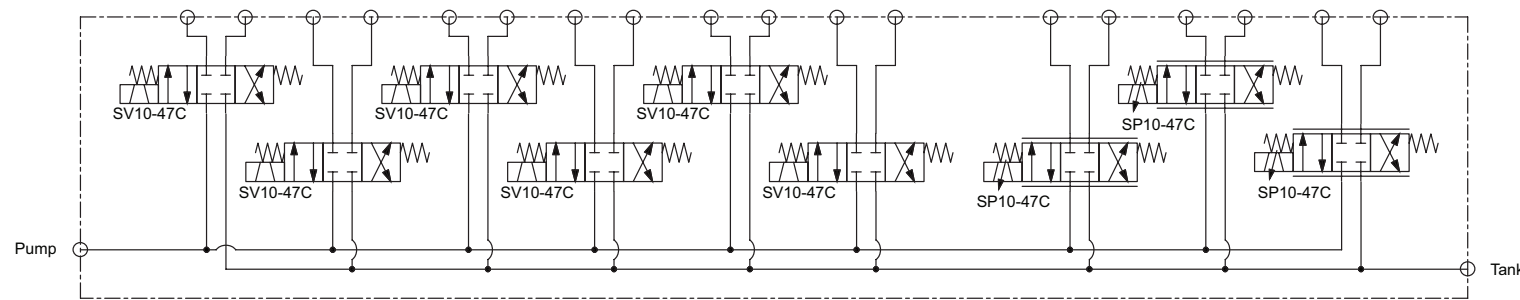

A HYPERFORMANCE™ SOLUTION TO PREVENT SWING MOTOR CAVITATION

Compact excavators often work in tight spaces and many have zero turn radius capability, which requires very smooth operation of swing or slewing function. The swing motor is often an open loop circuit requiring anti-cavitation. Here's an option for preventing anti-cavitation of the hydraulic motor for excavator swing/slew functions. This circuit also reduces the number of hydraulic fittings and leakage points.



LOW LEAKAGE BUCKET CONTROL

As excavator power and sophistication increase, so do flow rates. HydraForce SPCL16-40 valves control up to 152 lpm (40 gpm) while holding loads with extremely low leakage.

This directional control circuit has a multiple load sense configuration. The highest load sense signal supplied through the highest pressure pilot line is used to provide compensated flow to either end of the cylinder. The bottom load sense port signals the compensator, which allows each SPCL valve to provide a consistent amount of flow to each function, independent of load-induced pressure.

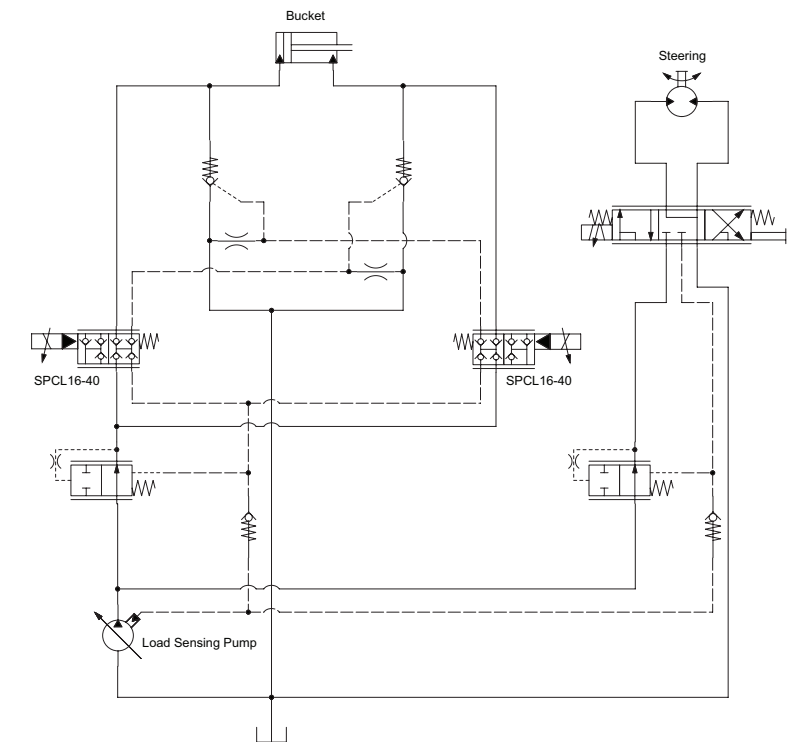

DIRECTIONAL BRIDGE

A bridge circuit provides complete control of lift and lower functions for excavators with low flow requirements. This configuration uses SPCL directional control valves, which eliminate additional load sense and load holding check valves. Both SPCL valves use load pressure as the piloting signal.

DIRECTIONAL BRIDGE CIRCUIT

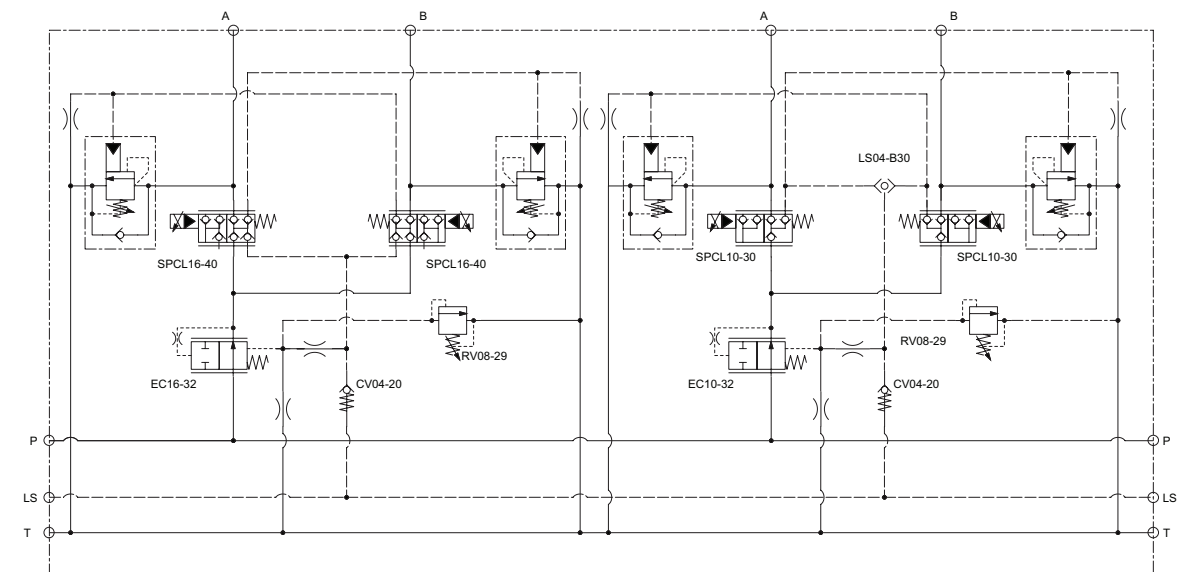

AUXILIARY FUNCTIONS

Excavators, especially the compact mini- and midi-sized models, can do much more than earth-moving and excavation. With the right attachments, an excavator can also be used for demolition, drilling, and material-handling – all with the power of electrohydraulic control.

HydraForce can provide hydraulic manifolds and valves for auxiliary functions on original equipment or aftermarket hydraulic attachment kits.

Our application engineering experts can work with you to correctly size and scale your hydraulic circuit for auxiliary functions ranging from augers, breakers and hammers to mowers, brush cutters and stump splitters.



HAMMER VALVE FOR BREAKER

This circuit provides responsive and smooth control of the fixed gear pump system for the breaker on a hydraulic excavator, using a solenoid valve, compensator, needle valve and relief valve. It has a maximum inlet flow of 180 lpm/47 gpm and a working pressure of 250 bar/3,625 psi.

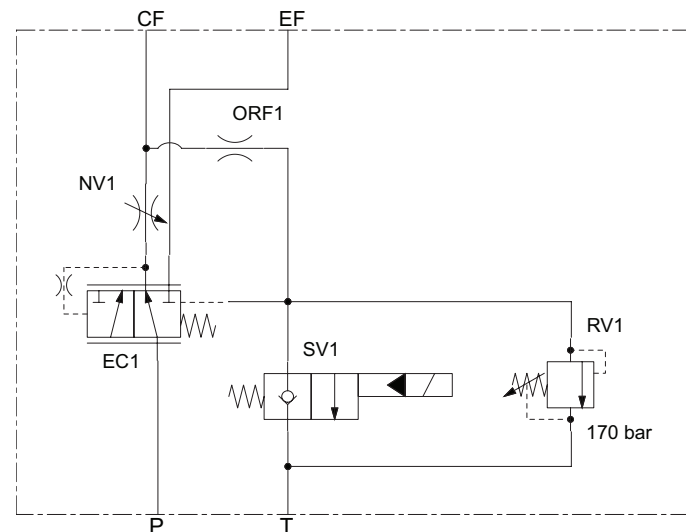

MAX INLET FLOW: 180 l/min / 47 gpm
MAX WORKING PRESSURE: 240 bar / 3500 psi

WEATHER-RESISTANT CONTROL OF ELECTRO-HYDRAULIC FUNCTIONS

For excavator applications requiring water and thermal-shock resistance, try our E-series solenoid coils which meet IP69K standards. A corrosion-resistant plating (G option) is also available on our entire line of cartridge valves to help guard against corrosion.



QUICK COUPLER MANIFOLD

A simple circuit consisting of a single solenoid, check and relief valve in a manifold provides fully customizable quick coupler for an attachment on a mini-excavator.

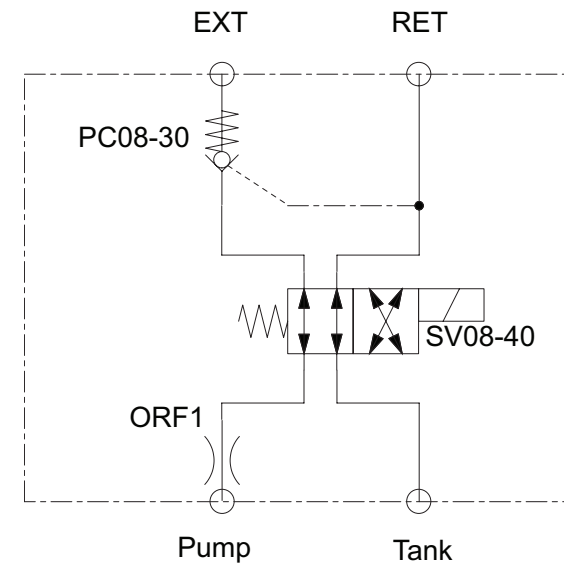

PILOT CONTROL MANIFOLD FOR A MINI-EXCAVATOR GRAPPLE

This simple circuit provides pilot control of hydraulic pressure for a 1 to 2.6 ton excavator. It uses two solenoid valves, a pressure relief valve and four check valves.

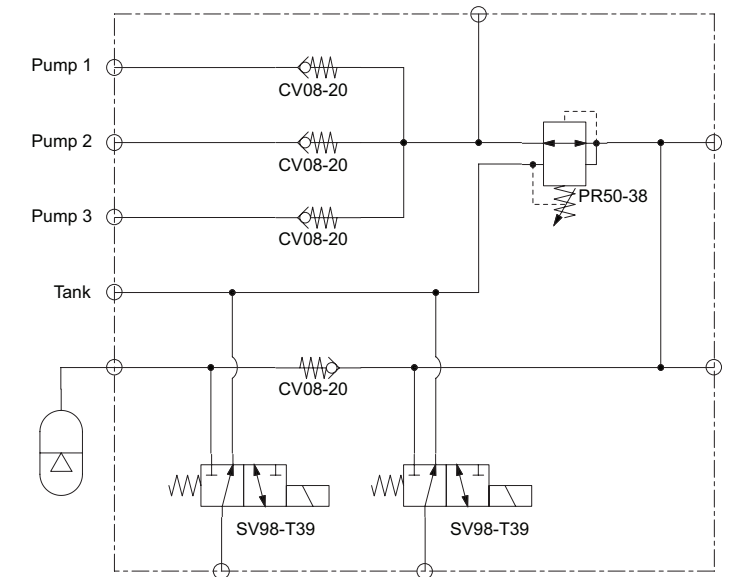

REDUCED-COST PILOT CONTROL MANIFOLD FOR A MIDI-EXCAVATOR

In order to reduce the main circuit pressure to a lower range for the auxiliary functions, there is often a large steel or ductile iron manifold which uses a pressure reducing valve to decrease the high inlet pressure. With the unique PRES50-30 valve, the secondary manifold for the lower pressure auxiliary functions can be aluminum, reducing both cost and weight. The main system pressure is plumbed directly into the steel adapter of the PRES50-30, which can withstand up to 5000 psi. In the adapter, pressure is reduced to between 450 and 800 psi for downstream functions. Specifying aluminum instead of steel for the manifold block, excavator manufacturers can reduce weight as well as cost for their machine. This circuit for an 8-ton excavator receives high pressure via the inlet of the PRES50-30 and reduces the pressure for use by the pilot control functions.

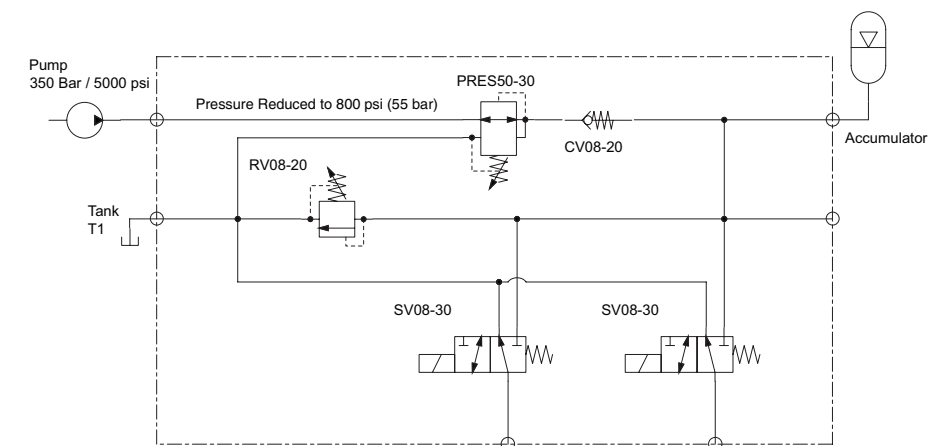

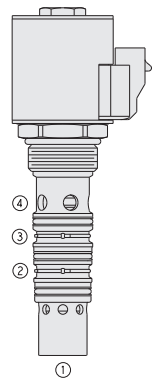

SPCL 16-40
Proportional Directional Control, 4-Port,
Normally Closed with Check Isolated
Load Sense

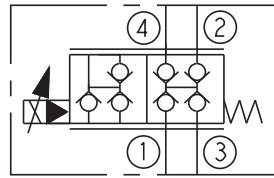

Flow: 152 lpm/40 gpm
Pressure: 250 bar (3625 psi)

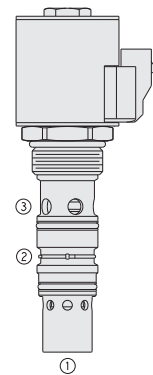

SPCL16-30
Proportional Flow Control Valve with
Integral Compensator

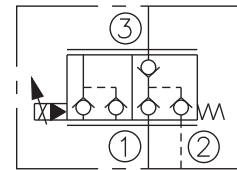

Flow: 132 lpm/35 gpm
Pressure: 350 bar (5075 psi)

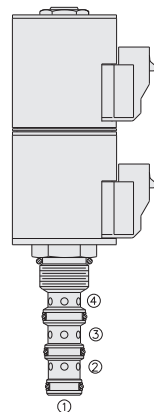

HSV10-47C
High Pressure Spool 4-Port, 3-Position,
Closed Center

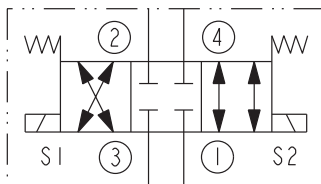

Flow: 37.9 lpm/10 gpm
Pressure: 350 bar (5075 psi)

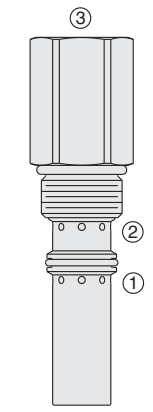

PRES50-30
Relief, Directing Acting Poppet with
Reverse Flow Check

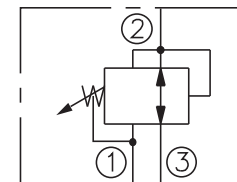

Flow: 115 lpm/30 gpm
Pressure: 420 bar (6100 psi)

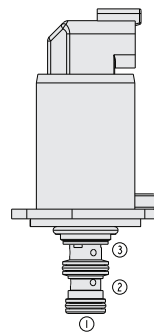

EHPR98-G3X
Proportional, Reducing / Relieving, Drop-in

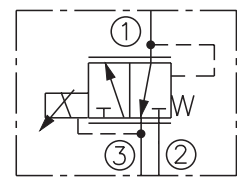

Flow: 4-6 lpm/1-1.4 gpm
Pressure: 20-30 bar (290-435 psi)

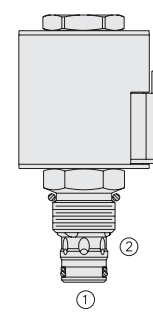

TSxx-27
Proportional Pressure Control, Pilot-
Operated Relief

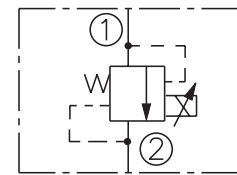

Flow: up to 189 lpm/50 gpm
Pressure: 241 bar (3500 psi)

OUR BREADTH OF PRODUCT

As the largest manufacturer of hydraulic cartridge valves in the world, HydraForce offers an extensive range of solenoid, electro-proportional, directional, flow, and pressure control valves. Last year, more than 200 new valves were introduced, including many high pressure and multi-function models. Cartridge valves for flow rates up to 379 lpm/100 gpm and operating pressures up to 350 bar/5,000 psi are sold individually, with housings or in manifold blocks. Valves can be custom-designed or standard product.

HydraForce designs, manufactures and supports valve, manifold and accessory products supported by heavy duty electronic machine control capabilities.

To request a free hydraulic integrated circuit (HIC) consultation, please visit:
<http://info.hydraforce.com/Free-Custom-Circuit-Consultation/>

PROGRAMMABLE MACHINE CONTROLLERS

It's easy to add electronic control to your hydraulic application with the HydraForce line of electronic control units (ECUs) and electronic valve drivers (EVDs).

HydraForce electronic controllers are designed to withstand the environmental demands of mobile, off-highway equipment applications. With flexible input and output configuration, these controllers can easily be customized for a wide variety of applications, including fan control, transmission and timed control applications, and more.

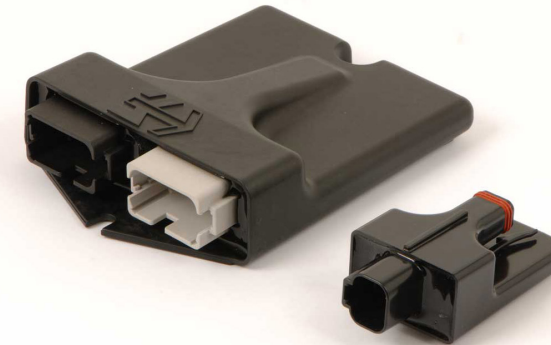

EVDR-ELECTRONIC VALVE DRIVERS

EVDRs are compact, economical and reliable electronic drivers for proportional solenoid valves. They mount directly onto the solenoid coil and are configurable using HF-Impulse software on a computer and serial cable or CAN to USB adapter.

EVDR-0101A

One input and one output. Input can be accepted from analog or digital operator interface devices.

EVDR-0201A

One or two outputs and one input that can be accepted from analog or SAE J1939 operator interface devices.

ECDR-0506A

Features six configurable inputs and five PWM outputs. This larger valve driver will be able to provide precise, repeatable control of four proportional valves and one on/off solenoid. The LED signal provides quick status check. The ECDR-0506A is CAN capable with CANopen and SAE J1939 protocols.

HF IMPULSE CONFIGURATION SOFTWARE

HydraForce has developed an easy-to-use configuration platform - HF-Impulse, available for free download from the HydraForce Electronics Portal at www.hydraforce.com/electronics. HF-Impulse allows you to flash devices with the latest firmware and configure all parameters for operation. You can configure any HydraForce electronic valve driver and select electronic controllers using HF-Impulse.

ECU-ELECTRONIC CONTROL UNITS

Model ECU-2415

Up to 39 digital, pulse, current measuring feedback and analog inputs along with 24 outputs consisting of up to 24 PWM or digital high-side drivers.



Model ECU-2820

Up to 52 inputs and 28 outputs consisting of up to 24 PWM or digital high-side drivers and up to four digital low-side drivers.

Model ECU-0809A

Features 8 flexible sourcing outputs, 9 flexible inputs, and 4 feedback inputs. This controller is built on a powerful 32-bit microprocessor and features a diagnostic indicator, unlimited F-RAM and CAN capability.

Model ECU-3233A

Features 65 pins with 32 outputs and 33 inputs that can be configured in multiple ways with CoDeSys software. Offers CAN capability with four ISO CAN 2.0B interfaces and an ethernet interface.



ECU-3233A

SENSOR VALVES

Select HydraForce valves can be ordered with an integral position sensing option capable of transmitting an on or off signal. This new sensing solution was designed for interchangeable use with existing HydraForce cartridge valves, is compatible with manual override options and uses an industry standard cavity.

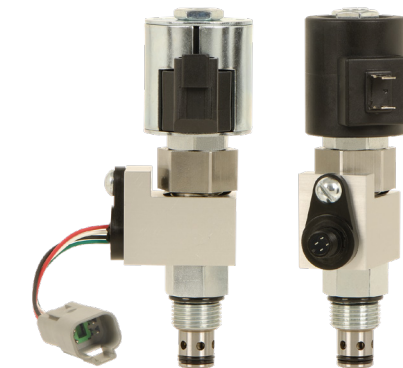

HEAVY DUTY SENSORS

HydraForce has accurate sensors designed for off-road applications.

Our temperature sensors are thermistor style with padded resistors.
ERT 120 – Output Signal: 5427.9 to 436.3 ohms

Our pressure sensors have 1% total error band accuracy, are IP67 rated.

ERP035 – for pressure ranges up to 35 bar (500 psi)
ERP414 – for higher pressures up to 414 bar (6000 psi)

OUR STORY

The HydraForce story began in 1985 when the company was founded near Chicago by several partners who saw the mobile equipment industry's need for quality hydraulic cartridge valves and manifolds delivered in a timely and responsive manner. They also saw the potential for engineering innovation and design flexibility offered by cost-effective and space-saving cartridge valves and hydraulic integrated circuits.

Since its founding, HydraForce continues to be a privately held company as it has grown to several manufacturing locations in North and South America, Europe and Asia, with a network of 120 stocking distributors who can offer local support across the globe.

To maintain our core competency of speed to market, HydraForce has invested in application technical support tools including i-Design, our free hydraulic system design software, which integrates seamlessly with 3rd party simulation software, monthly webinars on new products and application tips, and an online product catalog. All HydraForce products carry a five-year limited warranty against defects in material and workmanship.

OUR QUALITY AND MANUFACTURING GUARANTEE

All three HydraForce plants in North America, Europe and Asia follow the same manufacturing processes and standards to ensure global consistency in product quality.

- All products 100% tested
- Use of Lean and Six Sigma practices
- New product introduction tools such as:
 - Advanced Product Quality Planning (APQP)
 - Production Part Approval Process (PPAP)
 - Failure Mode and Effect Analysis (FMEA)
 - Statistical Process Control (SPC)
- Continuous improvement through Kaizen
- Responsive delivery with Kanban throughput system



OUR VISION:
 “To be an independent provider of innovative technical solutions that can change the world.”

OUR MISSION:
 “To provide our customers with the highest quality hydraulic valves and the most responsive customer support in the world.”



HYDRAFORCE TIMELINE

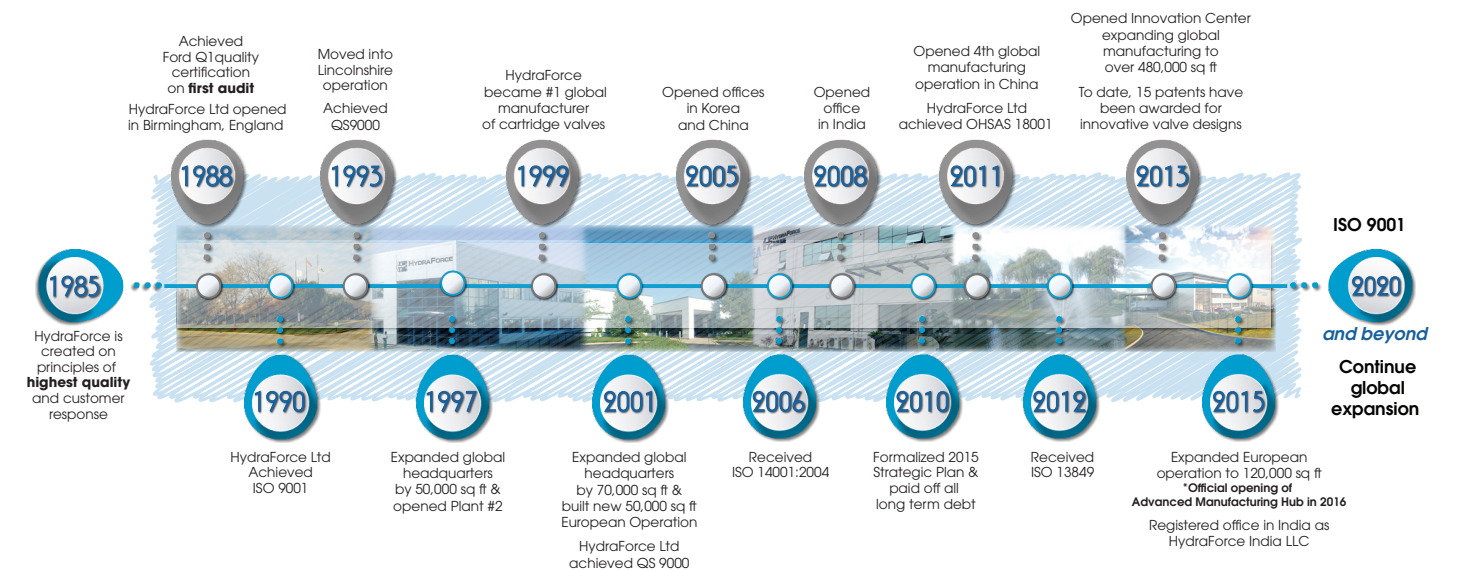

WORLDWIDE SUPPORT

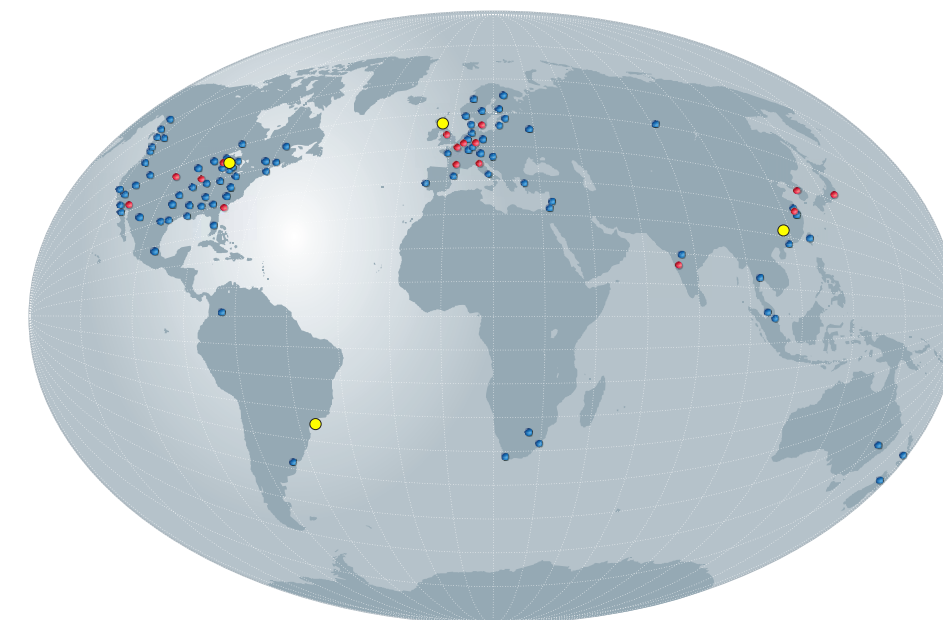

● MANUFACTURING ● TECHNICAL SALES ● DISTRIBUTION & SUPPORT

WHY CONSIDER HYDRAFORCE?



- World's largest privately owned cartridge valve manufacturer focused on electrohydraulic system controls
- Broadest range of cartridge valves
- Designed electrohydraulic systems for mobile equipment in every industry



- Integrate sensors, fittings, ancillary valves, and other custom components into a single manifold
- Simplified circuit design
- Consolidated or distributed hydraulic systems

- All manifolds are end-of-line function tested
- Use of Lean and Six Sigma practices
- Five year warranty on valves and manifolds

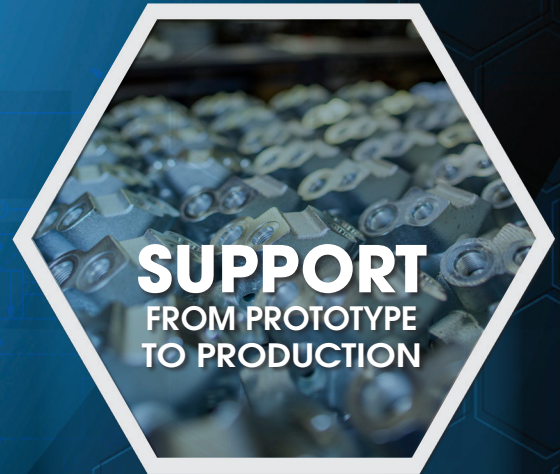

- Free design support
- Simulation software
- Fast prototypes



RoHS COMPLIANT HydraForce valve and manifold products comply with the European Council and Parliament RoHS directive 2002/95/EC limiting the use of hazardous substances. For all other products, consult factory.

© Copyright 2020 HydraForce, Inc. All rights reserved. HydraForce and the HydraForce logo are registered trademarks of HydraForce, Inc.