

Level Plus®

The *magnetostrictive* Level Sensors

MTS
SENSORS

MTS-SERVOCONTROLS

M-Series USTD II For Filling Stations

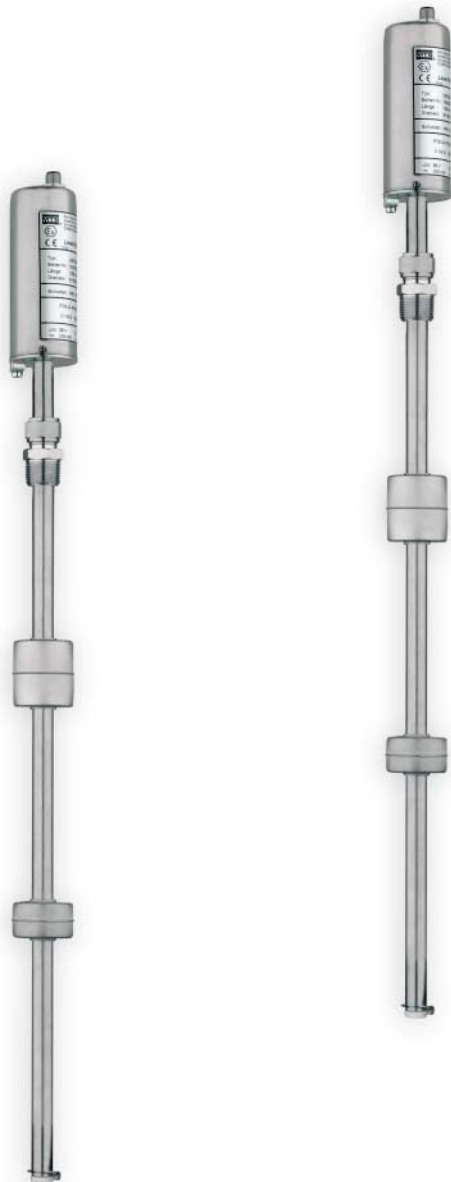

II 1/2G resp. II 2G
EEx ia IIB T4 resp. EEx ia IIA T4
PTB 04 ATEX 2107 X

- Continuous absolute level gauging
- Gauge order length 740 mm to 3800 mm (29 in. to 149 in.) in various length
- Only one probe for temperature, product and water levels
- Output: EIA RS 485 Interface
- 2-wire multidrop network
- Non-linearity 0,025%
- Repeatability 0,001%
- Intrinsically safe
- ATEX safety approvals for zones 0 and 1
- No recalibration needed

ISO 9001
CERTIFIED



M-Series USTD II

Product level, Interface level, temperature and volume shall be measured continuously, highly accurate and administrated. The best to do with LEVEL PLUS-USTDII, the precise, robust and pioneering tank gauge of MTS for gas stations.

At the same time it can measure the level of product and interface via two floats and, in addition, determine with 5 integrated digital thermometers the individual and average temperature of the thermometers submerged in the liquid. This serves in connection with a control unit to achieve exact calculations of value or mass in filling stations. For remote data transfer to the tank management system, the well-known digital RS 485-Interface is used.

- Easy to install
- No handling with fuel dip stick
- Measures product- and water level
- Continuous temperature control via 5 DT
- Absolute high-precision measurements
- No recalibration
- Replacement without tank opening

... only 3
safety barriers
per gas station

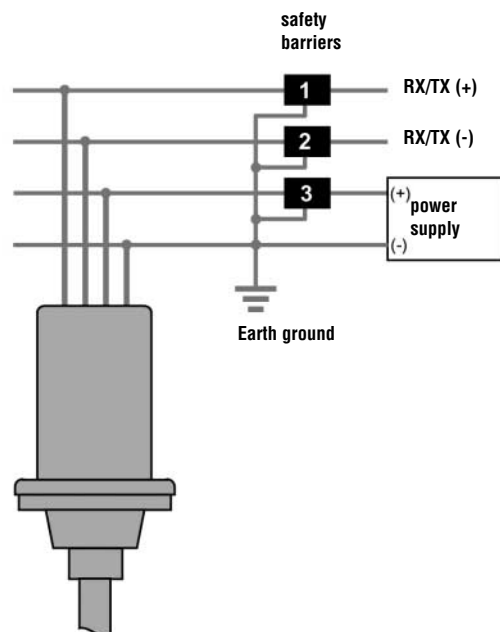

... up to 8 Sensors*
per Network

*extension up to 32 gauges

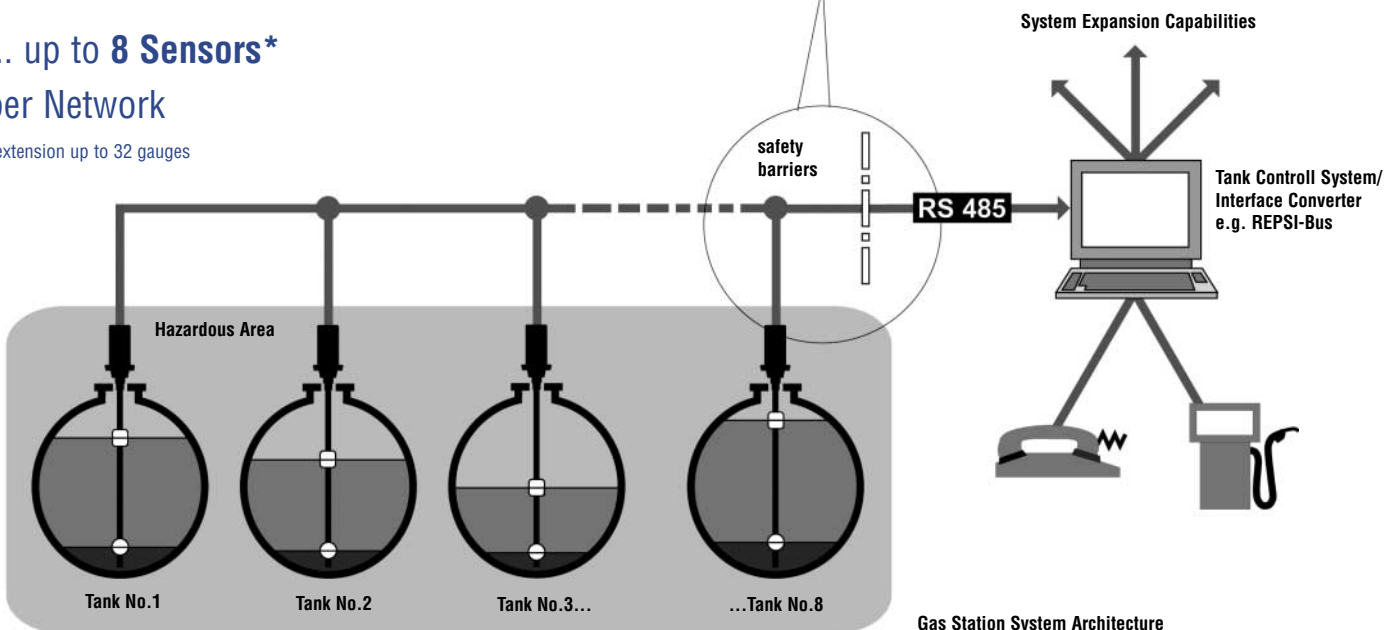

Gas Station System Architecture

LEVEL PLUS gauges are based on the magnetostrictive measuring technology, which is successfully used for more than 28 years at MTS.

Magnetostriction is a combination of magnetic (non contact) and ultrasonic effects (speed control).

According to MTS know-how, two magnetic fields interact, and a torsional strain pulse on the sensor element results. The running time of the pulse is used to determine the level measurement with a high degree of accuracy and reliability.

All LEVEL PLUS Tank Gauge systems base on this principle, which ensures a really innovative and promising measuring system for continuous level measurement.

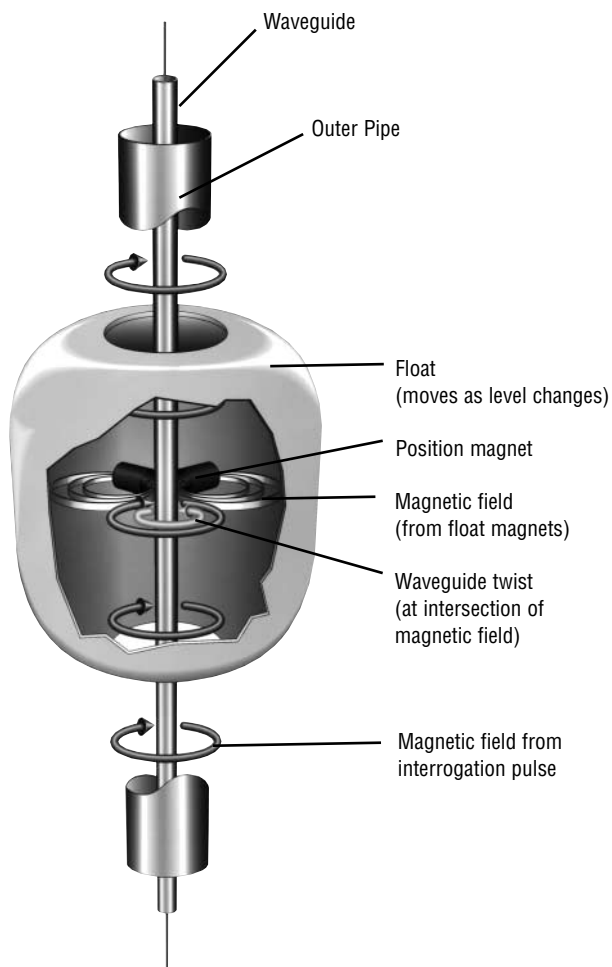

Materials / Mechanics

| | |
|-------------------|--|
| Sensorhead | Stainless steel 1.4301 |
| Sealing | IP 67; NEMA 6 |
| Sensor outer pipe | Stainless steel 1.4404 |
| Mounting | NPT fitting, flange |
| Float styles | Gas station: Stainless steel 1.4571 |
| Connection | 5-Pin connector, female M12 with 5 m pigtail, extra charge |
| Pressure rating | Up to 4 bar on stainless steel float Option: higher pressure floats on request |
| Safety approval | EC-Type-Examination Certificate II 1/2G bzw. II 2G EEx ia IIB T4 bzw. EEx ia IIA T4 PTB 04 ATEX 2107 X |

Measuring parameters / Electronics

| | |
|-------------------------|---|
| Measured variable | Product level, Interface level, temperature |
| Gauge length | 740 to 3800 mm |
| Non-Linearity | ≤ 0,025 % F.S. or 0,8 mm (whichever is greater) |
| Repeatability | ± 0,001% F.S. or 0,127 mm |
| Temperature measurement | 5 pcs DT for individual or average temperature, programmable. |
| - measuring range | -40°...+70°C |
| - repeatability | 0,28°C |
| Output format | Digital RS 485-Interface |
| Input voltage | 8-28 Vdc into Sensor |
| Current consumption | max. 10 mA |

Temperature requirements

| | |
|-----------------------|--|
| Storage temperature | -40°...+80°C |
| Operating temperature | -40°...+80°C (Sensorhead) -40°...+70°C (Sensorpipe) |

Interface float
Gasoline/Diesel; Water
Type 201 606-2

Product float
(Gasoline, Diesel)
Type 201 605-2

Floats

Illustrated at right are the standard floats for gas stations.

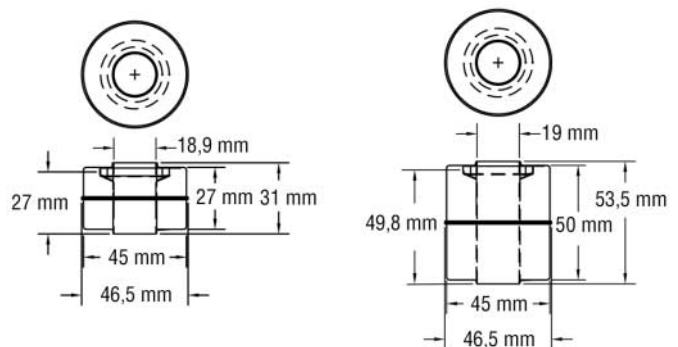

M-Series USTD II

Sensor Design

All LEVEL PLUS gauges, based on the non-contacting magnetostrictive technology, only have one moving part - the float. This simple design ensures no scheduled maintenance or recalibration will be required - ever.

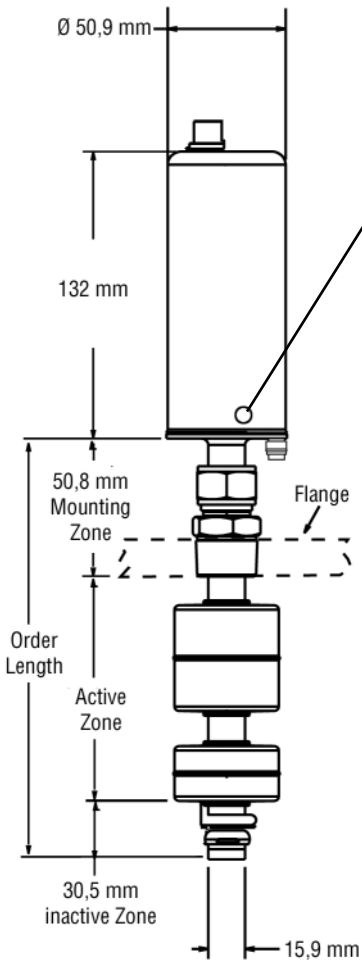

Remove Housing

Use a 2 mm inbus-key and turn the 2 screws clockwise into the housing-socket. Remove the housing carefully.

Mounting of housing

Push the housing carefully over the flange with O-Ring. Position the holes in line with the screws. Turn the screws anti-clockwise until they are in line with the outer surface of the housing.

The absolute measured level reading is also after a breakdown immediately thereafter available. The gauge is composed of three parts: The sensor rod with the integral sensing element for levels up to 3,8 mm and 5 DT for temperature measurements. The sensor head, a stainless steel housing with the sensor electronic and the float with a built-in magnet on the gauge pipe. Choosing the suitable second float, an additional measurement of the interface level is possible.

Ordering Guide

LEVEL PLUS-USTD II

Unit of measure

M - Millimeter (xxxx mm)
U - Inch (xxxx")

Gauge order length

From 740 to 3800 mm
(49 in. to 149 in.)

Mounting

- 6** - 3/4" / NPT adjustable fitting.
others e.g. 1"/1,5"/2" NPT or corresponding metric fitting (add. price)
- 8** - DIN- or ANSI-flange resp. welded fitting (add. price)
- H** - Fill tube mounting (hänger w. centering disk) Category 2-apparatus
- 7** - 5 m pigtail (blue), PG-fitting with strain-relief
- 9** - 5-pin plug, male contacts M12

Floats

- 1. Product float: Typ 201605-2 (Gasoline, Diesel)
- 2. Interface float: Typ 201606-2 (Gasoline/Diesel, Water)
- 3. Other floats: Upon request

